



## CHAPTER 7: Reinforced Concrete Column and Wall Footings

### 7.2 Pile Footings

---

#### Description

Pile supported footings or pile caps are used under columns and walls to distribute the load to the piles. The plan dimensions of a pile footing are determined by the number and the arrangement of the piles and the required minimum spacing between the piles. The pile arrangements assumed in this application are shown in detail in **Section 7.3**.

This application determines minimum required pile cap thickness and the maximum size and minimum number of reinforcing bars for pile caps with from 2 to 20 piles in a group. Pile diameter and spacing, and the size of the supported rectangular pier or wall may be specified by the user. The application uses the Strength Design Method of ACI 318-89.

The required input includes the pile capacity at service load (unfactored loads) and the plan dimensions of the column or wall. The user may also enter material properties and variables designated as "project constants" in this application.

The material properties include strength of the concrete and the reinforcement, unit weight of concrete, unit weight of reinforced concrete, and the preferred reinforcement ratio.

The project constants include pile diameter, minimum pile spacing, edge distance, and multiples used for rounding the pile coordinates, the pile cap depth and the plan dimensions of the pile caps.

A summary of input and calculated values are shown on pages 26-28.

**Reference:** ACI 318-89 "Building Code Requirements for Reinforced Concrete." (Revised 1992)

## Input

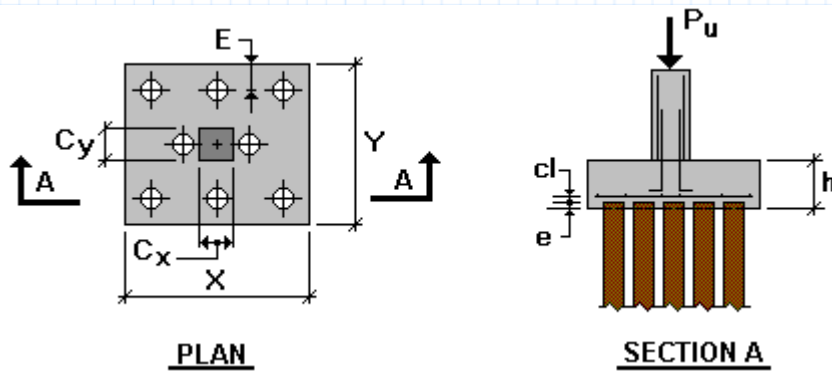

## Input Variables

Enter service load pile capacity, number of piles in group, and pier or wall dimensions.

Pile capacity at service loads:	$P_{cap} := 80 \text{ kip}$
Number of piles in group:	$N := 8$
Column width:	$C_x := 24 \text{ in}$
Column depth:	$C_y := 24 \text{ in}$

If the footing supports a wall, enter any wall length greater than or equal to the dimension of the footing parallel to the wall. The dimensions of the footing are shown on pages 9 and 10.

## Computed Variables

The following variables are calculated in this document:

$P_s$	total service load capacity of the piles
$F$	combined load factor for dead and live load
$P_u$	total factored load capacity of the piles and the pile cap
$q_u$	factored load capacity of one pile
$h$	total pile footing thickness
$X$	the longer dimension of the pile cap
$Y$	the shorter dimension of the pile cap
$x'$	pile coordinates in the X direction from the centroid of the pile group
$y'$	pile coordinates in the Y direction from the centroid of the pile group

## Input Constants

The following variables are normally constant for a given project and may be defined by the user. The variables  $s$ ,  $SzP$ ,  $SzD$  and  $E$  are used by this application to calculate the pile coordinates and plan dimensions of the pile caps.

Minimum pile spacing:	$s := 3 \text{ ft}$
Multiple for rounding pile spacing:	$SzP := 0.5 \text{ in}$
Multiple for rounding pile cap plan dimensions:	$SzD := 1 \text{ in}$
Minimum edge distance from center of pile:	$E := 1 \text{ ft} + 3 \text{ in}$

**Note** ⇒ Pile coordinates and pile cap plan dimensions for pile groups with 2 through 20 piles are calculated to the right starting at this point. (Scroll right to see.)

Ratio of live load to dead load:	$R := 1$
Pile diameter at top of pile:	$d_p := 8 \text{ in}$
Pile embedment into pile cap:	$e := 4 \text{ in}$
Clearance between reinforcement and top of pile:	$cl := 3 \text{ in}$
Multiple for rounding footing depths:	$SzF := 1 \text{ in}$

### Material Properties

Enter the values of  $f'_c$ ,  $f_y$ ,  $w_c$ ,  $w_{rc}$ ,  $k_v$  and  $k_w$ .

Specified compressive strength of concrete:	$f'_c := 4 \text{ ksi}$
Specified yield strength of reinforcement:	$f_y := 60 \text{ ksi}$
Unit weight of concrete:	$w_c := 145 \text{ pcf}$
Unit weight of reinforced concrete:	$w_{rc} := 150 \text{ pcf}$
Shear strength reduction factor for lightweight concrete $k_v = 1$ for normal weight, 0.75 for all-lightweight and 0.85 for sand-lightweight concrete (ACI 318, 11.2.1.2.):	$k_v := 1$
Weight factor for increasing development and splice lengths $k_w = 1$ for normal weight and 1.3 for lightweight aggregate concrete (ACI 318, 12.2.4.2.):	$k_w := 1$

Factors for use of lightweight concrete are included, but it would be unusual to use lightweight concrete for a pile cap.

Modulus of elasticity of reinforcement (ACI 318, 8.5.2):	$E_s := 29000 \text{ ksi}$
Strain in concrete at compression failure (ACI 318, 10.3.2):	$\varepsilon_c := 0.003$
Strength reduction factor for flexure (ACI 318, 9.3.2.1):	$\phi_f := 0.9$
Strength reduction factor for shear (ACI 318, 9.3.2.3):	$\phi_v := 0.85$

Reinforcing bar number designations, diameters, and areas:

$$N_o := [0 \ 1 \ 2 \ 3 \ 4 \ 5 \ 6 \ 7 \ 8 \ 9 \ 10 \ 11 \ 12 \ 13 \ 14 \ 15 \ 16 \ 17 \ 18]^T$$

$$d_b := [0 \ 0 \ 0 \ 0.375 \ 0.5 \ 0.625 \ 0.75 \ 0.875 \ 1.00 \ 1.128 \ 1.27 \ 1.41 \ 0 \ 0 \ 1.693 \ 0 \ 0 \ 0 \ 2.257]^T \text{ in}$$

$$A_b := [0 \ 0 \ 0 \ 0.11 \ 0.20 \ 0.31 \ 0.44 \ 0.60 \ 0.79 \ 1.00 \ 1.27 \ 1.56 \ 0 \ 0 \ 2.25 \ 0 \ 0 \ 0 \ 4.00]^T \text{ in}^2$$

Bar numbers, diameters and areas are in the vector rows (or columns in the transposed vectors shown) corresponding to the bar numbers. Individual bar numbers, diameters and areas of a specific bar can be referred to by using the vector subscripts as shown in the example below.

$$\text{Example: } N_{o_5} = 5 \quad d_{b_5} = 0.625 \text{ in} \quad A_{b_5} = 0.31 \text{ in}^2$$

The following values are computed from the entered material properties.

Modulus of elasticity of concrete (for values of  $w_c$  between 90 pcf and 155 pcf (ACI 318, 8.5.1):

$$E_c := \left( \frac{w_c}{\text{pcf}} \right)^{1.5} \cdot 33 \cdot \sqrt{\frac{f'_c}{\text{psi}}} \cdot \text{psi} \quad E_c = 3644 \text{ ksi}$$

Strain in reinforcement at yield stress:

$$\epsilon_y := \frac{f_y}{E_s} = 0.00207$$

Factor used to calculate depth of equivalent rectangular stress block (ACI 318, 10.2.7.3):

$$\beta_1 := \text{if} \left( (f'_c \geq 4 \cdot \text{ksi}) \cdot (f'_c \leq 8 \cdot \text{ksi}), 0.85 - 0.05 \cdot \frac{f'_c - 4 \cdot \text{ksi}}{\text{ksi}}, \text{if} ((f'_c \leq 4 \cdot \text{ksi}), 0.85, 0.65) \right) = 0.85$$

Reinforcement ratio producing balanced strain conditions (ACI 318, 10.3.2):

$$\rho_b := \frac{\beta_1 \cdot 0.85 \cdot f'_c}{f_y} \cdot \frac{E_s \cdot \epsilon_c}{E_s \cdot \epsilon_c + f_y} \quad \rho_b = 2.851\%$$

Maximum reinforcement ratio (ACI 318, 10.3.3):

$$\rho_{max} := \frac{3}{4} \cdot \rho_b \quad \rho_{max} = 2.138\%$$

Minimum reinforcement ratio for beams (ACI 318, 10.5.1, Eq. (10-3)):

$$\rho_{min} := \frac{200}{f_y} \text{ psi} \quad \rho_{min} = 0.333\%$$

Shrinkage and temperature reinforcement ratio (ACI 318, 7.12.2.1):

$$\rho_{temp} := \begin{cases} \text{if } f_y \leq 50 \text{ ksi} \\ 0.002 \end{cases} = 0.0018$$

$$\begin{cases} 0.002 - \frac{f_y}{60 \text{ ksi}} \cdot 0.0002 \\ \text{else if } \frac{0.0018 \cdot 60 \text{ ksi}}{f_y} \geq .0014 \\ \frac{0.0018 \cdot 60 \text{ ksi}}{f_y} \\ \text{else} \\ 0.0014 \end{cases}$$

Preferred reinforcement ratio:  $\rho := \frac{3}{8} \cdot \rho_b$

Any reinforcement ratio from  $\rho_{\min}$  (the minimum reinforcement ratio for flexure) to  $3/4\rho_b$  (the maximum reinforcement ratio) may be specified. Numerical values may also be entered directly, such as 1.0 % or 0.01.

Flexural coefficient K, for rectangular beams or slabs, as a function of  $\rho$  (ACI 318, 10.2):  
(Moment capacity  $\phi M_n = K(\rho)F$ , where  $F = bd^2$ )

$$K(\rho) := \phi_f \cdot \rho \cdot \left( 1 - \frac{\rho \cdot f_y}{2 \cdot 0.85 \cdot f'_c} \right) \cdot f_y$$

$$K(\rho) = 0.523 \text{ ksi}$$

Limit the value of  $f'_c$  for computing shear and development lengths to 10 ksi by substituting  $f'_{c_{\max}}$  for  $f'_c$  in formulas for computing shear and development lengths (ACI 318, 11.1.2, 12.1.2):

$$f'_{c_{\max}} := \text{if}(f'_c > 10 \cdot \text{ksi}, 10 \cdot \text{ksi}, f'_c)$$

Nominal "one way" shear strength per unit area in concrete (ACI 318, 11.3.1.1, Eq. (11-3), 11.5.4.3):

$$v_c := k_v \cdot 2 \cdot \sqrt{\frac{f'_{c_{\max}}}{\text{psi}}} \cdot \text{psi} \quad v_c = 126 \text{ psi}$$

Basic tension development length  $l_{dbt}$  (ACI 318, 12.2.2 and 12.2.3.6):

No. 3 through No. 11 bars:  $n := 3..11$

$$X1_n := 0.04 \cdot A_{b_n} \cdot \frac{f_y}{\sqrt{f'_{c_{\max}} \cdot \text{lb}f}} \quad X2_n := 0.03 \cdot d_{b_n} \cdot \frac{f_y}{\sqrt{\frac{f'_{c_{\max}}}{\text{psi}} \cdot \text{psi}}}$$

$$l_{dbt_n} := \text{if}(X1_n > X2_n, X1_n, X2_n)$$

$$l_{dbt}^T = [0 \ 0 \ 0 \ 10.7 \ 14.2 \ 17.8 \ 21.3 \ 24.9 \ 30 \ 37.9 \ 48.2 \ 59.2] \text{ in}$$

No. 14 bars:  $l_{dbt_{14}} := 0.085 \cdot \frac{f_y \cdot in^2}{\sqrt{f'_{c_{max}} \cdot lbf}} = 80.638 \text{ in}$

No. 18 bars  $l_{dbt_{18}} := 0.125 \cdot \frac{f_y \cdot in^2}{\sqrt{f'_{c_{max}} \cdot lbf}} = 118.585 \text{ in}$

Tension development length (ACI 318, 12.2.1):

No. 3 through No. 11 bars:

$$l_{dt_n} := \text{if}(k_w \cdot l_{dbt_n} \geq 12 \text{ in}, k_w \cdot l_{dbt_n}, \text{if}(k_w \cdot l_{dbt_n} > 0 \text{ in}, 12 \cdot \text{in}, 0 \text{ in})) = \begin{matrix} 12 \\ 14.23 \\ 17.788 \\ 21.345 \\ 24.903 \\ 29.978 \\ 37.947 \\ 48.193 \\ 59.198 \end{matrix} \text{ in}$$

No. 14 bars:  $l_{dt_{14}} := k_w \cdot l_{dbt_{14}} = 80.638 \text{ in}$

No. 18 bars  $l_{dt_{18}} := k_w \cdot l_{dbt_{18}} = 118.585 \text{ in}$



## Calculations

Service load:

$$P_s := P_{cap} \cdot N = 640 \text{ kip}$$

Combined load factor for dead + live load:

$$F := \frac{1.4 + 1.7 \cdot R}{1 + R} = 1.55$$

Factored load  $P_u$ :

$$P_u := F \cdot N \cdot P_{cap} = 992 \text{ kip}$$

Factored load per pile:

$$q_u := \frac{P_u}{N} = 124 \text{ kip}$$

The longer dimension of the pile cap:

$$X = 8.5 \text{ ft}$$

The shorter dimension of the pile cap:

$$Y = 7.75 \text{ ft}$$

Range variable  $i$  from 0 to the number of piles  $N$ , minus 1:

$$i := 0..N - 1$$

Pile coordinates in the X direction from the centerline of the pile group, starting from top left to bottom right:

$$x'^T = [-3 \ 0 \ 3 \ -1.5 \ 1.5 \ -3 \ 0 \ 3] \text{ ft}$$

Pile coordinates in the Y direction from the centerline of the pile group, starting from left to right and top to bottom:

$$y'^T = [2.625 \ 2.625 \ 2.625 \ 0 \ 0 \ -2.625 \ -2.625 \ -2.625] \text{ ft}$$

## Calculations to determine the minimum required footing depth for flexure, $d_f$

Bending moment about the Y axis as function of distance  $x_2$  from Y axis:

$$M_y(x_2) := \sum_i \left( q_u \cdot \left( \text{if} \left( x'_i \leq x_2, 0 \cdot \text{ft}, x'_i - x_2 \right) \right) \right)$$

Bending moment about the Y axis at face of pier:

$$M_y \left( \frac{C_x}{2} \right) = 558 \text{ kip} \cdot \text{ft}$$

Bending moment about the X axis as function of distance  $y_2$  from X axis:

$$M_x(y_2) := \sum_i \left( q_u \cdot \left( \text{if} \left( y'_i \leq y_2, 0 \cdot \text{ft}, y'_i - y_2 \right) \right) \right)$$

Bending moment about the X axis at face of pier:

$$M_x \left( \frac{C_y}{2} \right) = 604.5 \text{ kip} \cdot \text{ft}$$

Effective footing width for bending about the X axis, at face of pier:

$$X_f := \text{if} \left( N \neq 3, X, A + \left( E + \frac{2}{3} \cdot s_2 - \frac{C_y}{2} \right) \cdot \left( \frac{X - A}{Y - B} \right) \right) = 8.5 \text{ ft}$$

Effective footing widths for flexure and shear vary with distance from the pile group centroid for the 3-pile group. The remaining pile caps are rectangular in shape and the full width is effective for flexure or shear at any section.

Effective footing width at face of pier, for bending about the Y axis:

$$Y_f := Y - \text{if} \left( (N \neq 3) + (C_x \leq A), 0 \cdot ft, \left( \frac{C_x - A}{X - A} \cdot (Y - B) \right) \right) = 7.75 \text{ ft}$$

Maximum bending moment per unit width:

$$M_u := \text{if} \left( \frac{M_x \left( \frac{C_y}{2} \right)}{X_f} > \frac{M_y \left( \frac{C_x}{2} \right)}{Y_f}, \frac{M_x \left( \frac{C_y}{2} \right)}{X_f}, \frac{M_y \left( \frac{C_x}{2} \right)}{Y_f} \right) = 72 \frac{\text{kip} \cdot \text{ft}}{\text{ft}}$$

Minimum required effective footing depth for flexure at specified reinforcement ratio (ACI 318, 10.2):

$$d_f := \sqrt{\frac{M_u}{K(\rho)}} = 11.735 \text{ in}$$

**Calculations to determine the minimum required footing depth for one-way beam shear,  $d_{bm}$**

Shear  $V_{ux}(x2)$  in the X direction as a function of any specified positive distance  $x2$  from the Y axis (ACI 318, 15.5.3):

$$V_{ux}(x2) := \left( \sum_i \text{if} \left( x'_i \leq \left( \frac{C_x}{2} + \frac{d_p}{2} \right), 0, \text{if} \left( x'_i \geq \left( x2 + \frac{d_p}{2} \right), 1, \text{if} \left( x'_i \leq \left( x2 - \frac{d_p}{2} \right), 0, \frac{x'_i + \frac{d_p}{2} - x2}{d_p} \right) \right) \right) \right) \cdot q_u$$

Shear  $V_{uy}(y2)$  in the Y direction as a function of any specified positive distance  $y2$  from the X axis (ACI 318, 15.5.3):

$$V_{uy}(y2) := \left( \sum_i \text{if} \left( y'_i \leq \left( \frac{C_y}{2} + \frac{d_p}{2} \right), 0, \text{if} \left( y'_i \geq \left( y2 + \frac{d_p}{2} \right), 1, \text{if} \left( y'_i \leq \left( y2 - \frac{d_p}{2} \right), 0, \frac{y'_i + \frac{d_p}{2} - y2}{d_p} \right) \right) \right) \right) \cdot q_u$$

Since the 3-pile group is not rectangular the effective width in the X and Y directions varies with distance from the pile group centroid. The shear must be checked at both the inside edge of the piles and at distance  $d$  from the face of the pier.

The following functions are for calculating the effective widths and required depths at any positive distance from the pile group centroid, and the required depths at distance  $d$  from the face of the pier. The largest required depth at distance  $d$  from the face of pier or at the inside edge of the piles determines the minimum required depth for the 3-pile group.

Effective footing width for one-way shear in the Y direction for the 3-pile group, as a function of any positive distance  $y2$  from the X axis:

$$X_3(y2) := A + (E + \max(y') - y2) \cdot \left( \frac{X - A}{V - R} \right)$$



Minimum required depth for one-way shear in the Y direction for the 3-pile group as a function of any positive distance y2 from the X axis:

$$d_{y3}(y2) := \text{if} \left( y2 \leq \frac{C_y}{2}, 0 \cdot \text{ft}, \text{if} \left( \frac{V_{uy}(y2)}{\phi_v \cdot v_c \cdot X_3(y2)} < y2 - \frac{C_y}{2}, \frac{V_{uy}(y2)}{\phi_v \cdot v_c \cdot X_3(y2)}, y2 - \frac{C_y}{2} \right) \right)$$

Effective footing width for one-way shear in the X direction for the 3-pile group, as a function of any positive distance x2 from the Y axis:

$$Y_3(x2) := Y - \text{if} \left( \frac{C_x}{2} + x2 \leq \frac{A}{2}, 0 \cdot \text{ft}, (C_x + 2 \cdot x2 - A) \cdot \left( \frac{Y - B}{X - A} \right) \right)$$

Minimum required depth for one-way shear in the X direction for the 3-pile group as a function of any positive distance x2 from the Y axis:

$$d_{x3}(x2) := \text{if} \left( x2 \leq \frac{C_x}{2}, 0 \cdot \text{ft}, \text{if} \left( \frac{V_{ux}(x2)}{\phi_v \cdot v_c \cdot Y_3(x2)} < x2 - \frac{C_x}{2}, \frac{V_{ux}(x2)}{\phi_v \cdot v_c \cdot Y_3(x2)}, x2 - \frac{C_x}{2} \right) \right)$$

Minimum required depth for one-way shear in the X direction for the 3-pile group at distance d from face of pier:

Constraint Values	$d := 1 \text{ ft}$
	$d \leq \max(x') + \frac{d_p}{2} \quad \frac{V_{ux} \left( \frac{C_x}{2} + d \right)}{\phi_v \cdot v_c \cdot Y_3 \left( \frac{C_x}{2} + d \right)} = d$
Solver	$d_{x3\_d}(d) := \text{Find}(d)$

Minimum required depth for one-way shear in the Y direction for the 3-pile group at distance d from face of pier:

Constraint Values	$d := 1 \text{ ft}$
	$d \leq \max(y') + \frac{d_p}{2} \quad \frac{V_{uy} \left( \frac{C_y}{2} + d \right)}{\phi_v \cdot v_c \cdot X_3 \left( \frac{C_y}{2} + d \right)} = d$
Solver	$d_{y3\_d}(d) := \text{Find}(d)$

### **Functions for rectangular pile caps**

The following PTC Mathcad solve blocks contain the functions for determining the required depth for one-

way shear for the rectangular pile caps.

Minimum required depth for one-way shear in the X direction at distance d from face of pier:

$$\begin{array}{l}
 \text{Constr. Values} \\
 d := 1 \text{ ft} \\
 d \leq \max(x') + \frac{d_p}{2} \quad \frac{V_{ux} \left( \frac{C_x}{2} + d \right)}{\phi_v \cdot v_c \cdot Y} = d \\
 \text{Solver} \\
 d_x(d) := \text{Find}(d)
 \end{array}$$

Minimum required depth in the Y direction at distance d from face of pier:

$$\begin{array}{l}
 \text{Constr. Values} \\
 d := 1 \text{ ft} \\
 d \leq \max(y') + \frac{d_p}{2} \quad \frac{V_{uy} \left( \frac{C_y}{2} + d \right)}{\phi_v \cdot v_c \cdot X} = d \\
 \text{Solver} \\
 d_y(d) := \text{find}(d)
 \end{array}$$

$$d := 1 \text{ ft}$$

Depth required for one-way shear in the X & Y directions:

$$d_x := \text{if} \left( N \neq 3, d_x(d), \max \left( \left[ \begin{array}{l} d_{x3} \left( \max(x') - \frac{d_p}{2} \right) \\ d_{x3\_d}(d) \end{array} \right] \right) \right) = 21.171 \text{ in}$$

$$d_y := \text{if} \left( N \neq 3, d_y(d), \max \left( \left[ \begin{array}{l} d_{y3} \left( \max(y') - \frac{d_p}{2} \right) \\ d_{y3\_d}(d) \end{array} \right] \right) \right) = 19.015 \text{ in}$$

Minimum depth required for beam shear:

$$d_{bm} := \max \left( \left[ \begin{array}{l} d_x \\ d_y \end{array} \right] \right) = 21.171 \text{ in}$$

**Calculations to determine the minimum required footing depth for peripheral shear,  $d_{per}$**   
(ACI 318, 11.12.2.1)

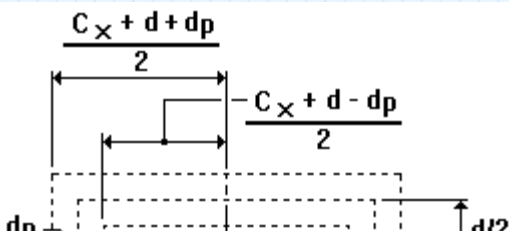

**Critical Sections for Peripheral Shear**  
(d is the effective depth and  $d_p$ )

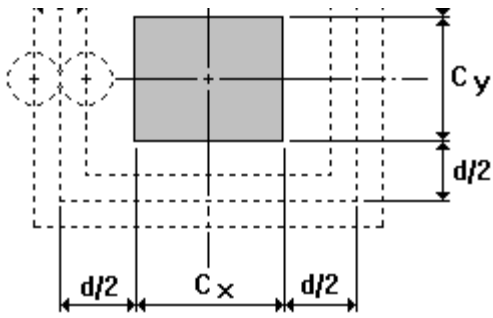

is the pier diameter)

Perimeter of critical section for slabs and footings expressed as a function of  $d$  (ACI 318, 11.12.1.2):

$$b_o(d) := 2 \cdot (C_x + C_y + 2 \cdot d)$$

Ratio of the longer to the shorter pier dimension (ACI 318 11.12.2.1):

$$\beta_c := \text{if} \left( (C_x \geq C_y), \frac{C_x}{C_y}, \frac{C_y}{C_x} \right) \quad \beta_c = 1$$

Nominal "two way" concrete shear strength per unit area in slabs and footings, expressed as a function of effective depth  $d$ . Since piers or columns are at the center of the pile cap they are considered "interior" columns for calculating two way shear, and  $\alpha_s$  is equal to 40. (ACI 318 11.12.2.1, Eqs. (11-36), (11-37) and (11-38)):

$$\alpha_s := 40$$

$$v_{cp}(d) := \min \left[ \begin{array}{l} \left( 2 + \frac{4}{\beta_c} \right) \\ \frac{\alpha_s \cdot d}{b_o(d)} \\ 4 \end{array} \right] \cdot k_v \cdot \sqrt{\frac{f'_{c\_max}}{\text{psi}}} \cdot \text{psi}$$

$k_v$  and  $f'_{c\_max}$  are defined on pages 5 and 7, respectively.

Function  $V1(d)$  computes a vector with elements equal to 0 if the pile produces shear on the critical section and 1 if it does not:

$$V1(d) := \overrightarrow{\left( |x'| \leq \frac{C_x + d - d_p}{2} \right) \cdot \left( |y'| \leq \frac{C_y + d - d_p}{2} \right)}$$

Function  $V2(d)$  computes a vector with elements equal to 1 if the full reaction of the pile produces shear on the critical section and 0 if it does not:

$$V2(d) := \overrightarrow{\left( |x'| \geq \frac{C_x + d + d_p}{2} \right) + \left( |y'| \geq \frac{C_y + d + d_p}{2} \right) > 0}$$

Function  $V3(d)$  computes a vector with elements equal to 1 if a portion of the pile reaction produces shear on the critical section and 0 if it does not:

$$V3(d) := 1 - V1(d) - V2(d)$$

Function V4(d) computes a vector with elements equal to the the larger difference between the x' or y' pile coordinate and the corresponding distance to the shear section minus half the pile diameter or 0 ft.

$$V4(d) := \begin{pmatrix} d_{xtemp} \leftarrow \left( \frac{C_x + d - d_p}{2} \right) \\ d_{ytemp} \leftarrow \left( \frac{C_y + d - d_p}{2} \right) \\ \frac{V3(d) \cdot \langle |x'| - d_{xtemp} > 0 \text{ ft} \rangle \cdot \langle |x'| - d_{xtemp} \rangle + V3(d) \cdot \langle |y'| - d_{ytemp} > 0 \text{ ft} \rangle \cdot \langle |y'| - d_{ytemp} \rangle}{2} \end{pmatrix}$$

Shear  $V_{up}(d)$  on the peripheral shear section at distance  $d/2$  from the face of the pier, expressed as a function of  $d$  (ACI 318, 15.5.3):

$$V_{up}(d) := \sum \left( \left( V2(d) + \frac{V4(d)}{d_p} \right) \cdot q_u \right)$$

Guess value of  $d$ :  $d := d_{bm}$

$$d'_{per}(d) := \text{root} \left( \frac{V_{up}(d)}{b_o(d) \cdot d} - \phi_v \cdot v_{cp}(d), d \right)$$

$$d'_{per} := \text{if} \left( \langle (C_x + d_{bm}) \geq X \rangle + \langle (C_y + d_{bm}) \geq Y \rangle, d_{bm}, d'_{per}(d) \right) = 19.816 \text{ in}$$

Minimum depth for peripheral shear  $d_{per}$ :

$$d_{per} := \text{if} \left( \langle (C_x + d'_{per}) \geq X \rangle + \langle (C_y + d'_{per}) \geq Y \rangle, d_{bm}, d'_{per} \right) = 19.816 \text{ in}$$

If either dimension of the critical shear section is greater than the corresponding pile cap dimension, peripheral shear is not critical and the depth for peripheral shear is defined as equal to the depth required for one-way shear.

### **Calculation to determine the minimum required depth for deep beam shear $d_{bm2}$**

(ACI 318, 11.8, using Eq. (11-30) for shear strength)

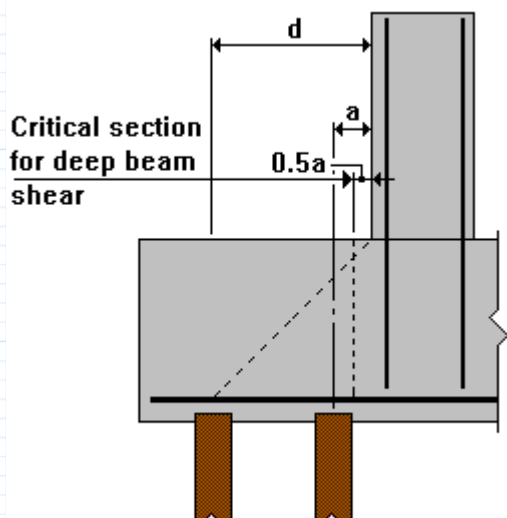

Shear spans in the X and Y directions are one-half the distances between the closest pile row and the face of the pier (See ACI 318, Chapter 11 Notation, and 11.8):

$$0.5 \cdot a_x = 0.25 \text{ ft}$$

$$0.5 \cdot a_y = 0.813 \text{ ft}$$

Moment and shear in the X and Y directions on the critical shear sections at distance  $0.5a_x$  and  $0.5a_y$  from the face of the pier (ACI 318, 15.5.3):

$$M_y \left( \frac{C_x}{2} + 0.5 \cdot a_x \right) = 465 \text{ kip} \cdot \text{ft} \quad M_x \left( \frac{C_y}{2} + 0.5 \cdot a_y \right) = 302.25 \text{ kip} \cdot \text{ft}$$

$$V_{uy} \left( \frac{C_y}{2} + 0.5 \cdot a_y \right) = 372 \text{ kip} \quad V_{ux} \left( \frac{C_x}{2} + 0.5 \cdot a_x \right) = 356.5 \text{ kip}$$

Ratios of moment to shear  $R_x$  and  $R_y$ , at the critical sections for deep beam shear in the X and Y directions: Ratios of moment to shear  $R_x$  and  $R_y$ , at the critical sections for deep beam shear in the X and Y directions:

$$R_x := \frac{M_y \left( \frac{C_x}{2} + 0.5 \cdot a_x \right)}{V_{ux} \left( \frac{C_x}{2} + 0.5 \cdot a_x \right)} = 1.304 \text{ ft} \quad R_y := \frac{M_x \left( \frac{C_y}{2} + 0.5 \cdot a_y \right)}{V_{uy} \left( \frac{C_y}{2} + 0.5 \cdot a_y \right)} = 0.813 \text{ ft}$$

Multipliers for use in ACI 318, Eq. (11-30):

$$KX(d) := \text{if} \left( 3.5 - 2.5 \cdot \frac{R_x}{d} < 1, 1, \text{if} \left( 3.5 - 2.5 \cdot \frac{R_x}{d} > 2.5, 2.5, 3.5 - 2.5 \cdot \frac{R_x}{d} \right) \right)$$

$$KY(d) := \text{if} \left( 3.5 - 2.5 \cdot \frac{R_y}{d} < 1, 1, \text{if} \left( 3.5 - 2.5 \cdot \frac{R_y}{d} > 2.5, 2.5, 3.5 - 2.5 \cdot \frac{R_y}{d} \right) \right)$$

Nominal deep beam shear stress at factored load in the X and Y directions (ACI 318, 11.8.7, Eq. (11-30)) with  $\rho_w$  conservatively assumed equal to minimum temperature reinforcement,  $\rho_{temp}$ :

$$v_{cx}(d) := \min \left[ \left[ KX(d) \cdot \left( \left( 1.9 \cdot \sqrt{\frac{f'_c}{\text{psi}}} + 2500 \cdot \rho_{temp} \cdot \frac{d}{R_x} \right) \cdot \text{psi} \right) \right], \left[ 6 \cdot \sqrt{\frac{f'_c}{\text{psi}}} \cdot \text{psi} \right] \right]$$

$$v_{cy}(d) := \min \left[ \left[ KY(d) \cdot \left( \left( 1.9 \cdot \sqrt{\frac{f'_c}{\text{psi}}} + 2500 \cdot \rho_{temp} \cdot \frac{d}{R_y} \right) \cdot \text{psi} \right) \right], \left[ 6 \cdot \sqrt{\frac{f'_c}{\text{psi}}} \cdot \text{psi} \right] \right]$$

Effective depth required in the X direction for deep beam shear:

$$\text{Guess value of } d: \quad d := d_x$$

$$d_{bm2\_x} := \text{root} \left( \frac{V_{ux} \left( \frac{C_x}{2} + 0.5 \cdot a_x \right)}{\phi_v \cdot v_{cx}(d) \cdot \text{if} \left( N \neq 3, Y, Y_3 \left( \frac{C_x}{2} + 0.5 \cdot a_x \right) \right)} - d, d \right) = 21.381 \text{ in}$$

$$v_{cx}(d_{bm2\_x}) = 210.9 \text{ psi}$$

Effective depth required in the Y direction for deep beam shear:

$$\text{Guess value of } d: \quad d := d_y$$

$$d_{bm2\_y} := \text{root} \left( \frac{V_{uy} \left( \frac{C_y}{2} + 0.5 \cdot a_y \right)}{\phi_v \cdot v_{cy}(d) \cdot \text{if} \left( N \neq 3, X, X_3 \left( \frac{C_y}{2} + 0.5 \cdot a_y \right) \right)} - d, d \right) = 16.556 \text{ in}$$

$$v_{cy}(d_{bm2\_y}) = 259.2 \text{ psi}$$

Depth required for deep beam shear is the larger value of  $d_{bm2}$ :

$$d_{bm2} := \max \left( \left[ \begin{array}{l} d_{bm2\_x} \\ d_{bm2\_y} \end{array} \right] \right) = 21.381 \text{ in}$$

**Calculations to determine the minimum required depth for beam shear or peripheral shear for one corner pile,  $d_{cor}$**

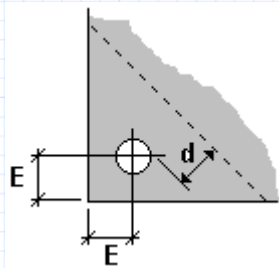

**Critical Section for  
Beam Shear  
for 1 corner pile**

**Required depth for beam shear for one corner pile**

$$\text{Guess value of } d: \quad d := 1 \cdot ft$$

$$d_{cor\_1} := \text{root} \left( \frac{q_u}{\phi_v \cdot v_c \cdot (d_p + 2 \cdot d + 2 \cdot \sqrt{2} \cdot E)} - d, d \right) = 14.515 \text{ in}$$

**Required depth for peripheral shear for one corner pile**

Nominal "two way" concrete shear strength per unit area in slabs and footings, expressed as a function of effective depth  $d$ . For a corner pile  $\alpha_s$  is equal to 20. Since  $\beta_c$  is 1 for piles in this application, ACI 318 Eq. (11-36) is not critical (ACI 318, 11.12.2.1, Eqs. (11-37) and (11-38)):

$$\alpha_s := 20 \quad b_o(d) := \left( (d_p + d) \cdot \frac{\pi}{4} + 2 \cdot E \right)$$



$$v_{cp}(d) := \min \left( \left[ \frac{\alpha_s \cdot d}{b_o(d)} + 2 \right], \left[ \frac{4}{4} \right] \right) \cdot k_v \cdot \sqrt{\frac{f'_{c\_max}}{psi}} \cdot psi$$

$$d_{cor\_2} := \text{root} \left( \frac{q_u}{\phi_v \cdot v_{cp}(d) \cdot (b_o(d))} - d, d \right) = 12.507 \text{ in}$$

Depth required for one corner pile is the larger value of  $d_{cor}$ :

$$d_{cor} := \max \left( \left[ d_{cor\_1} \right], \left[ d_{cor\_2} \right] \right) = 14.515 \text{ in}$$

### Depth required for a single interior pile, $d_{one}$

Nominal "two way" concrete shear strength per unit area for one interior pile, expressed as a function of effective depth  $d$ . For an interior pile  $\alpha_s$  is equal to 40 Since  $\beta_c$  is 1 for piles in this application ACI 318 Eq. (11-36) is not critical. (ACI 318 11.12.2.1, Eqs. (11-37) and (11-38)):

$$\alpha_s := 40$$

$$b_o(d) := \pi \cdot (d_p + d)$$

$$v_{cp}(d) := \min \left( \left[ \frac{\alpha_s \cdot d}{b_o(d)} + 2 \right], \left[ \frac{4}{4} \right] \right) \cdot k_v \cdot \sqrt{\frac{f'_{c\_max}}{psi}} \cdot psi$$

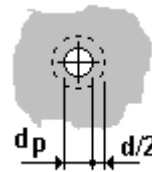

$$d_{one} := \text{root} (b_o(d) \cdot d \cdot \phi_v \cdot v_{cp}(d) - q_u, d) = 10.126 \text{ in}$$

### Depth required for two interior piles, $d_{two}$

Nominal "two way" concrete shear strength per unit area for two interior piles, expressed as a function of effective depth  $d$ . For interior piles  $\alpha_s$  is equal to 40 (ACI 318, 11.12.2.1, Eqs. (11-37) and (11-38)):

$$\alpha_s := 40$$

$$\beta_c(d) := \frac{s + d + d_p}{d_p + d}$$

$$b_o(d) := \pi \cdot (d_p + d) + (2 \cdot s + d)$$

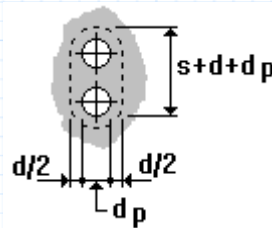

$$v_{cp}(d) := \min \left( \left[ 2 + \frac{4}{\beta_c(d)} \right], \left[ \frac{\alpha_s \cdot d}{b_o(d)} + 2 \right], \left[ \frac{4}{4} \right] \right) \cdot k_v \cdot \sqrt{\frac{f'_{c\_max}}{psi}} \cdot psi$$

Depth,  $d_{two}$ , required for two adjacent piles is equal to  $d_{one}$  unless overlapping shear perimeters require a greater depth when spacing  $s$  is less than  $d_{one} + d_p$ :

$$d_{two} := \text{if}(d_p + d_{one} \leq s, d_{one}, \text{root}((b_o(d) \cdot d) \cdot \phi_v \cdot v_{cp}(d) - 2 \cdot q_u, d)) = 10.126 \text{ in}$$

Minimum thickness for a footing on piles (ACI 318, 15.7):

$$d_{min} := 12 \text{ in}$$

### Minimum required effective depth, $d_e$

Largest effective depth determined by flexure, one-way beam shear, peripheral shear, deep beam shear, shear on a single corner pile, a single interior pile, two adjacent piles, or the minimum thickness required for a footing on piles  $d_e$ :

$$\begin{bmatrix} d_f \\ d_{bm} \\ d_{per} \\ d_{bm2} \\ d_{cor} \\ d_{one} \\ d_{two} \\ d_{min} \end{bmatrix} = \begin{bmatrix} 11.735 \\ 21.171 \\ 19.816 \\ 21.381 \\ 14.515 \\ 10.126 \\ 10.126 \\ 12 \end{bmatrix} \text{ in} \quad d_e := \max \begin{bmatrix} d_f \\ d_{bm} \\ d_{per} \\ d_{bm2} \\ d_{cor} \\ d_{one} \\ d_{two} \\ d_{min} \end{bmatrix} = 21.381 \text{ in}$$

### Calculations to determine the largest permissible reinforcing bar sizes

Maximum available lengths in the X direction for development of reinforcement:

$$L_{dx} := \frac{X - C_x}{2} - 3 \text{ in} \quad L_{dx} = 3 \text{ ft}$$

Maximum available lengths in the Y direction for development of reinforcement. The available development length for the 3-pile group is calculated from face of pier to the pile at the apex of the group:

$$L_{dy} := \text{if}\left(N \neq 3, \frac{Y - C_y}{2}, \frac{\frac{2}{3} \cdot s2 + E - \frac{C_y}{2}}{\sin(\alpha)}\right) - 3 \cdot \text{in} \quad L_{dy} = 2.625 \text{ ft}$$

Index numbers of maximum bar sizes determined by available development lengths:

$$index_0 := 0 \quad index_{0..n} := \text{if}(l_{dt_n} \leq L_{dx}, n, index_0)$$

$$bx := index_0 = 8$$

$$index_0 := 0 \quad index_{0..n} := \text{if}(l_{dt_n} \leq L_{dy}, n, index_0)$$

$$by := index_0 = 8$$

Sizes of the largest permissible reinforcing bars for the X and Y directions. Since the 3-pile group uses three equal bands of reinforcement the maximum bar size is defined as the smaller bar size for either the X or Y direction:

$$BarSize_X := \text{if}(N \neq 3, bx, \min(\{bx\})) = 8 \quad BarSize_Y := \text{if}(N \neq 3, by, \min(\{by\})) = 8$$

$$BarSize\_X := \text{if} \left( N \neq 3, bx, \min \left( \left\lfloor \frac{bx}{by} \right\rfloor \right) \right) = 8$$

$$BarSize\_Y := \text{if} \left( N \neq 3, by, \min \left( \left\lfloor \frac{by}{bx} \right\rfloor \right) \right) = 8$$

$$bx := BarSize\_X$$

$$d_{b_{bx}} = 1 \text{ in}$$

$$by := BarSize\_Y$$

$$d_{b_{by}} = 1 \text{ in}$$

Total pile cap thickness rounded up to the nearest multiple of SzF:

$$h := SzF \cdot \text{ceil} \left( \frac{d_e + d_{b_{bx}} + 0.5 \cdot d_{b_{by}} + cl + e}{SzF} \right) = 30 \text{ in}$$

Pile cap weight:

$$CapWt := CapArea \cdot h \cdot w_{rc} = 24.703 \text{ kip}$$

### Calculation to determine the required number of reinforcing bars in the X and Y directions

Effective depths in the X and Y directions:

$$d_{ex} := h - e - cl - 0.5 \cdot d_{b_{bx}} = 22.5 \text{ in}$$

$$d_{ey} := h - e - cl - d_{b_{bx}} - 0.5 \cdot d_{b_{by}} = 21.5 \text{ in}$$

Total required flexural reinforcement area in the X direction:

$$A_{sx\_flex} := \left( Y_f \cdot d_{ex} \cdot \left( \left( \left( \left( \sqrt{1 - \frac{2 \cdot M_y \left( \frac{C_x}{2} \right)}{\phi_f \cdot Y_f \cdot d_{ex}^2 \cdot 0.85 \cdot f'_c}} \right)} \right) \cdot \frac{0.85 \cdot f'_c}{f_y} \right) \right) \right) = 5.646 \text{ in}^2$$

Minimum required reinforcement area for shrinkage and temperature in the X direction (ACI 318, 7.12):

$$A_{sx\_temp} := \rho_{temp} \cdot h \cdot Y = 5.022 \text{ in}^2$$

Larger required reinforcement in the X direction:

$$A_{sx} := \max \left( \left[ \begin{array}{l} A_{sx\_flex} \\ A_{sx\_temp} \end{array} \right] \right) = 5.646 \text{ in}^2$$

Total required reinforcement area for flexure in the Y direction:

$$A_{sy\_flex} := \text{if} \left( N \neq 2, \left( X_f \cdot d_{ey} \cdot \left( \left( \left( \sqrt{1 - \frac{2 \cdot M_x \left( \frac{C_y}{2} \right)}{\phi_f \cdot X_f \cdot d_{ey}^2 \cdot 0.85 \cdot f'_c}} \right)} \right) \cdot \frac{0.85 \cdot f'_c}{f_y} \right) \right), 0 \text{ in}^2 \right) = 6.414 \text{ in}^2$$

Minimum required reinforcement area for shrinkage and temperature in the Y direction (ACI 318, 7.12):

$$A_{sy\_temp} := \rho_{temp} \cdot h \cdot X = 5.508 \text{ in}^2$$

Larger required reinforcement in the Y direction:

$$A_{sy} := \max \left( \left[ \begin{array}{l} A_{sy\_flex} \\ A_{sy\_temp} \end{array} \right] \right) = 6.414 \text{ in}^2$$

Minimum number of bars to limit spacing of reinforcement to 18 inches (ACI 318, 7.6.5):

$$\left( \frac{Y - 6 \cdot \text{in}}{18} \right)$$

$$MinNumb\_X := \text{ceil} \left( \frac{Y - 6 \cdot in}{18 \cdot in} + 0.5 \right) = 6$$

$$MinNumb\_Y := \text{ceil} \left( \frac{X - 6 \cdot in}{18 \cdot in} + 0.5 \right) = 6$$

Maximum bar areas corresponding to minimum specified spacing:

$$MinA\_x := \frac{A_{sx}}{MinNumb\_X} = 0.941 \text{ in}^2 \qquad MinA\_y := \frac{A_{sy}}{MinNumb\_Y} = 1.069 \text{ in}^2$$

Index numbers of bar sizes determined by minimum specified spacing:

$$index_0 := 0 \qquad index_{0.n} := \text{if} \left( A_{b_n} \leq MinA\_x, n, index_0 \right)$$

$$ax := index_0 \qquad ax = 8$$

$$index_0 := 0 \qquad index_{0.n} := \text{if} \left( A_{b_n} \leq MinA\_y, n, index_0 \right)$$

$$ay := index_0 \qquad ay = 9$$

Actual bar sizes in the X and Y directions.

Bar sizes in the X and Y directions (the smaller bar area determined by the required total reinforcement or the specified minimum spacing). The bar size in the Y direction of the 2-pile group is set at 3:

$$BarSize\_X := \text{if} \left( \left( M_y \left( \frac{C_x}{2} \right) = 0 \text{ kip} \cdot \text{ft} \right) + (ax \leq bx), ax, bx \right) = 8$$

$$BarSize\_Y := \text{if} \left( N \neq 2, \text{if} \left( \left( M_x \left( \frac{C_y}{2} \right) = 0 \text{ kip} \cdot \text{ft} \right) + (ay \leq by), ay, by \right), 3 \right) = 8$$

Subscript variables cx and cy defined as the bar sizes in the X and Y directions, respectively:

$$cx := BarSize\_X \qquad cy := BarSize\_Y$$

### **Adjustments required in reinforcement areas for the 3-pile group**

In the the 3-pile group the reinforcement is customarily placed in 3 bands of equal area, over the pile centers. Because the bands are at an angle to the axes of bending the reinforcement areas must be adjusted accordingly.

Total required reinforcement area in each of 3 bands for the 3-pile group:

$$A_{sx} := \text{if} \left( N \neq 3, A_{sx}, \text{if} \left( \frac{A_{sx}}{2 \cdot \sin(\alpha)} > \frac{A_{sy}}{1 + \cos(\alpha)}, \frac{A_{sx}}{2 \cdot \sin(\alpha)}, \frac{A_{sy}}{1 + \cos(\alpha)} \right) \right) = 5.646 \text{ in}^2$$

$$A_{sy} := \text{if} \left( N \neq 3, A_{sy}, A_{sx} \right) = 6.414 \text{ in}^2$$

Number of bars required in the X and Y directions. The number of bars in Y direction of the 2-pile group is set at a multiple of 18 inches:

$$Numb\_X := \text{ceil} \left( \frac{A_{sx}}{A_{bcx}} \right) = 8$$

$$Numb\_Y := \text{if} \left( N \neq 2, \text{ceil} \left( \frac{A_{sy}}{A_{bcy}} \right), \text{ceil} \left( \frac{X}{18 \text{ in}} \right) \right) = 9$$

## Summary

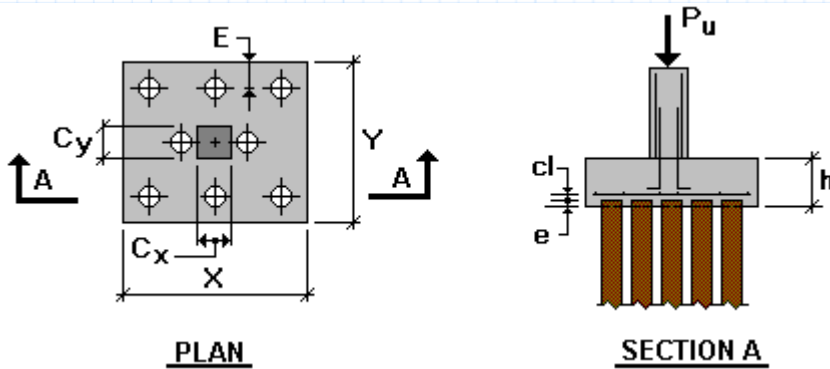

Pile capacity at service loads:

$$P_{cap} = 80 \text{ kip}$$

Number of piles in group:

$$N = 8$$

Pile diameter at top of pile:

$$d_p = 8 \text{ in}$$

Pile embedment into pile cap:

$$e = 4 \text{ in}$$

Clearance between reinforcement and top of pile:

$$cl = 3 \text{ in}$$

Specified compressive strength of concrete:

$$f'_c = 4 \text{ ksi}$$

Specified yield strength of reinforcement:

$$f_y = 60 \text{ ksi}$$

Unit weight of concrete:

$$w_c = 145 \text{ pcf}$$

Unit weight of reinforced concrete:

$$w_{rc} = 150 \text{ pcf}$$

Minimum pile spacing:

$$s = 3 \text{ ft}$$

Minimum edge distance from center of pile:

$$E = 1.25 \text{ ft}$$

Column or wall width:

$$C_x = 24 \text{ in}$$

Column depth or wall thickness:

$$C_y = 24 \text{ in}$$

Ratio of live load to dead load:

$$R = 1$$

Multiple for rounding pile spacing:

$$SzP = 0.5 \text{ in}$$

Multiple for rounding pile cap plan dimensions:

$$SzD = 1 \text{ in}$$

Multiple for rounding footing depths:

$$SzF = 1 \text{ in}$$

Specified reinforcement ratio:

$$\rho = 1.069\%$$



### *Computed Variables*

Combined load factor for dead and live load:  $F = 1.55$

Total service load capacity of the piles  
and the pile cap:  $P_s = 640 \text{ kip}$

Total factored load capacity of the piles  
and the pile cap:  $P_u = 992 \text{ kip}$

Number of reinforcing bars in the X direction:  $Numb\_X = 8$

Bar size in the X direction:  $BarSize\_X = 8$

Number of reinforcing bars in the Y direction:  $Numb\_Y = 9$

Bar size in the Y direction:  $BarSize\_Y = 8$

The number and size of reinforcing bars for the 3-pile group is shown as equal in the X and Y directions. The reinforcement for the 3-pile group consists of three equal bands over the three centerlines of the piles, with the number and size of bars of the bars in each band equal to that shown for the X and Y directions.

Longer dimension  
of the pile cap:  $X = 8.5 \text{ ft}$

Shorter dimension  
of the pile cap:  $Y = 7.75 \text{ ft}$

Total pile footing  
thickness:  $h = 30 \text{ in}$

Total pile cap weight:  $CapWt = 24.703 \text{ kip}$