

This is the landing area where I want the gate to be and therefore the face/surface I want to split.

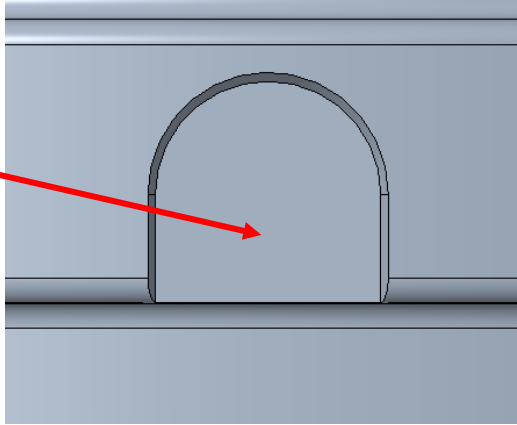

After following the mentioned steps and trying to split vertically and horizontally this is what I end up with. Surfaces around the intended surface get split, but the surface I want to be split remains intact.

