



AEROSPACE,
DEFENCE & RAILWAY

Analysis of Bolted Connections in Creo Simulate

- Theory, Software Functionality and Application Examples -

Dr.-Ing. Roland Jakel, Altran Aviation Engineering

5th SAXSIM, TU Chemnitz
Rev. 1.1 | April 23rd, 2013

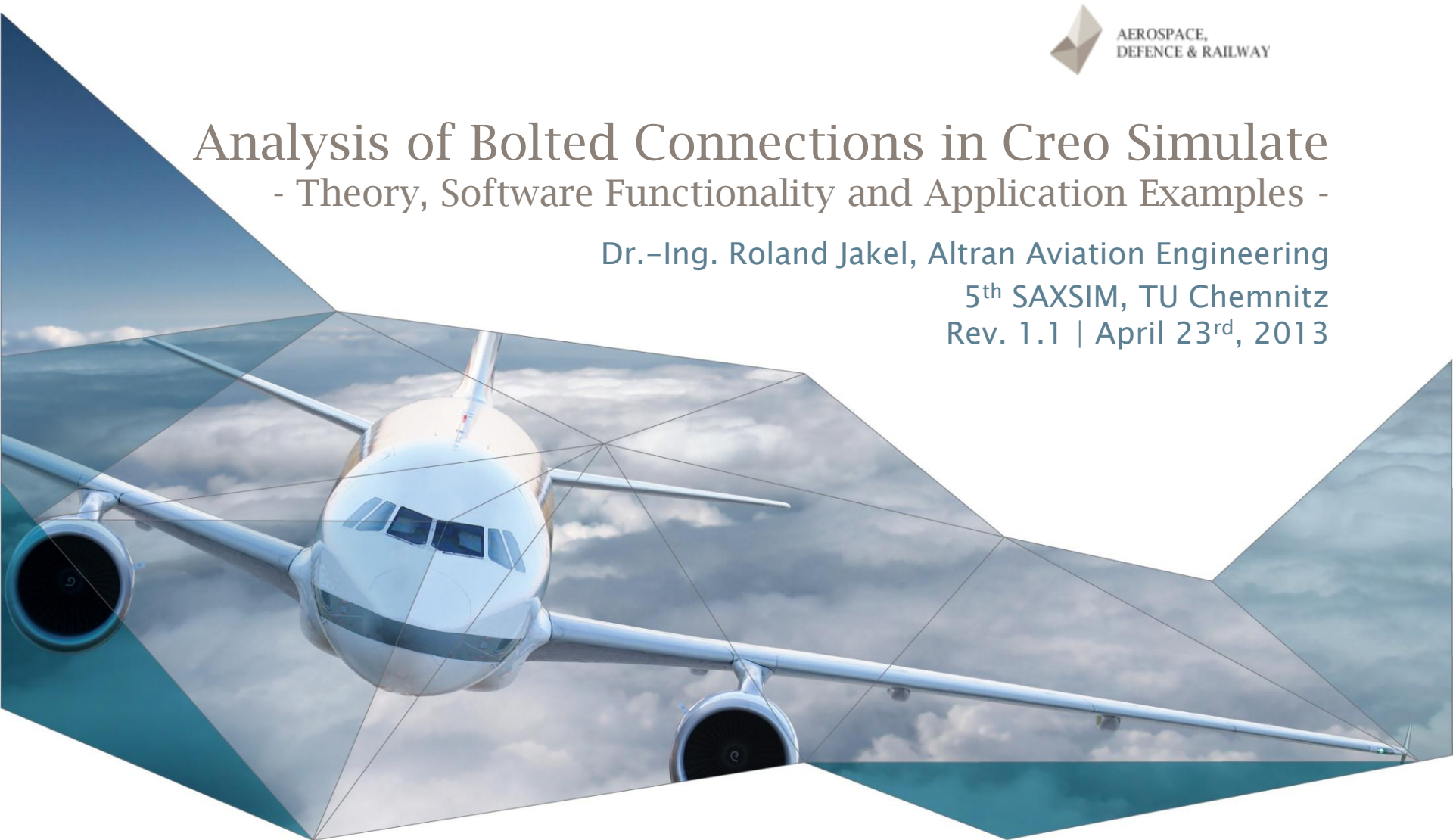

CONTENTS

Part A: Theory & Software Functionality

- | | | |
|----|---|-------|
| 1. | Refresher: Theoretical foundations of bolt analysis | 6-10 |
| 2. | Building FEM-models of bolted connections | |
| | 2.1 FEM model classes according to VDI 2230 part 2 | 11-12 |
| | 2.2 Creo Simulate features suitable for these model classes | 13 |
| 3. | Linearization of bolted connections for the FEM analysis | |
| | 3.1 Requirements | 14-15 |
| | 3.2 Linear analysis without preload | 16-17 |
| 4. | Idealization of bolts in Creo Simulate | |
| | 4.1 The improved fastener feature since Creo Simulate 1.0 | 18-33 |
| | 4.2 Pretension elements | 34-35 |
| | 4.3 More methods of idealization | 36-37 |
| | 4.4 Current software limitations | 38-39 |

CONTENTS (cont'd)

Part B: Advanced Application Examples

- | | |
|---|-------|
| 1. Bolts with elasto-plasticity and complex load history (tightening, embedding) | 41-51 |
| 2. Additional fastener loadings because of thin flanges and eccentric load introduction | 52-55 |

Part C: Appendix

- | | |
|--------------------|-------|
| 1. List of Sources | 58-61 |
| 2. Acknowledgement | 62 |

Core competencies

alTran

Space



Rail



IT



MSI
(Mechanical
Systems
Installation)

Systems
Engineering

Materials

Engine

Supply chain & PMO
Manufacturing processes

Manufacturing
Engineering

Research &
Technology

Electrical Systems
Installation

Non Conformity
Management

Business
Management

Quality & Project
Management

Structure
Design & Stress

New mutual transverse offers:
Industrialisation
SC & Program Management

TECCON

alTran

Core competencies

alTRan

TECCON

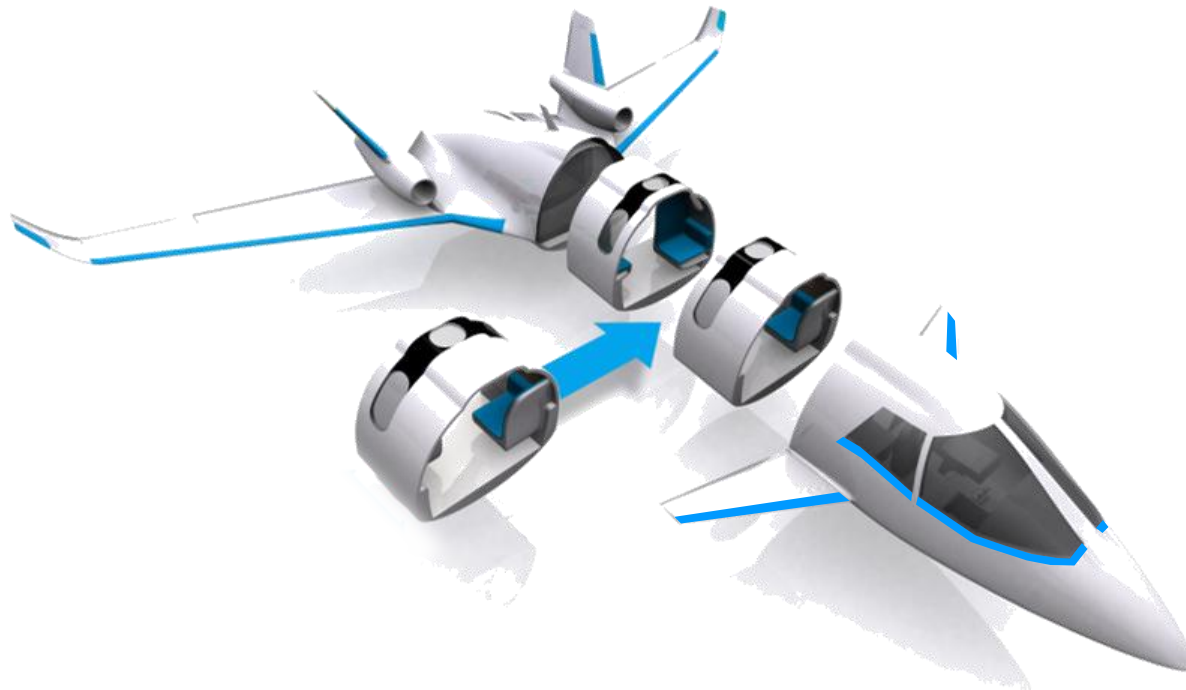

Largest & most complete
ASDR supplier

alTRan

Part A: Theory & Software Functionality

1. **Refresher: Theoretical foundations of bolt analysis**
2. **Building FEM-models of bolted connections**
 - 2.1 FEM model classes according to VDI 2230 part 2
 - 2.2 Creo Simulate features suitable for these model classes
3. **Linearization of bolted connections for the FEM analysis**
 - 3.1 Requirements
 - 3.2 Linear analysis without preload
4. **Idealization of bolts in Creo Simulate**
 - 4.1 The improved fastener feature since Creo Simulate 1.0
 - 4.2 Pretension elements
 - 4.3 More methods of idealization
 - 4.4 Current software limitations

Part A: Theory & Software Functionality

1. Refresher: Theoretical foundations of bolt analysis

Functional principle of a bolted connection

- No preload (bolt too short, plates too thick)

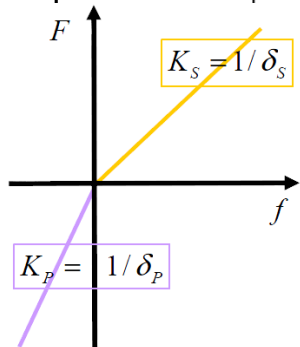
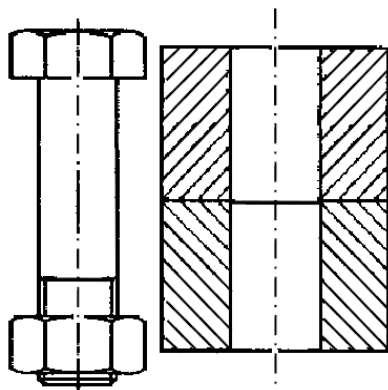

- Preloaded with mounting force F_M (serial connection)

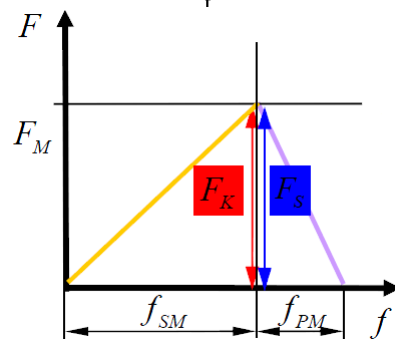
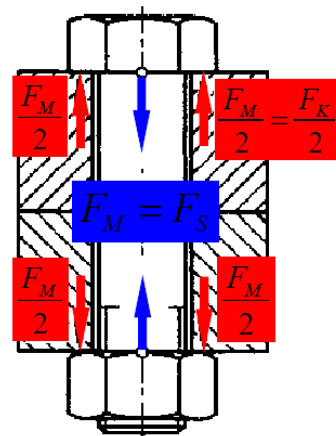

- Operational Force F_A acts below bolt head (parallel connection)

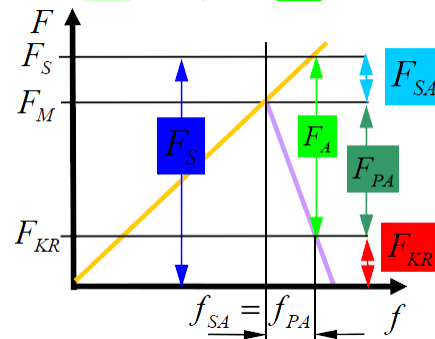
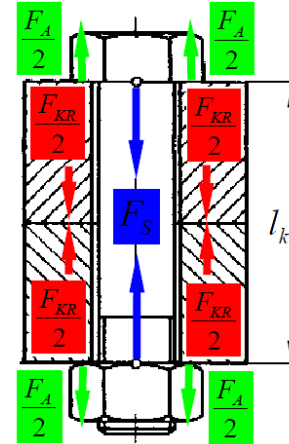

- Operational Force F_A acts within the plates (part of the plates becomes bolt spring)

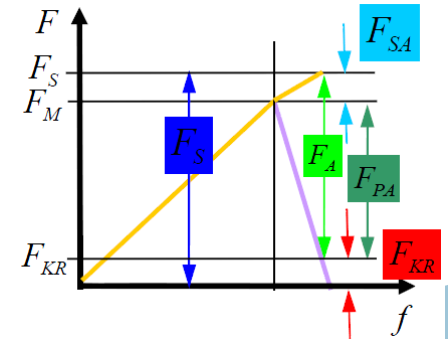
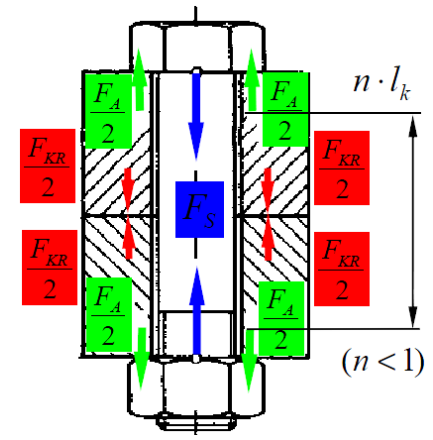

Part A: Theory & Software Functionality

1. Refresher: Theoretical foundations of bolt analysis

Basic definitions in bolt analysis acc. to VDI 2230

Basic equations and quantities

- The real load factor Φ_n describes, which part F_{SA} of the axial operational force F_A loads the bolt in addition to the preload F_M :
 - » axial additional bolt load: $F_{SA} = \Phi_n \cdot F_A$
 - » additional plate load (unloading): $F_{PA} = (1 - \Phi_n) \cdot F_A$
 - » remaining clamp load: $F_{KR} = F_M - (1 - \Phi_n) \cdot F_A$
- For the analytical calculation of Φ_n , VDI 2230 defines the ideal load factor Φ_k , which only depends on the geometry of the bolted parts and the used materials (E-modulus), but not on the load introduction location
 - » The ideal load factor $\Phi_k = \delta_p / (\delta_s + \delta_p)$ usually can be computed by standard equations for the elastic resilience of bolt δ_s and plate δ_p
 - » The load introduction location within the plates is taken into account afterwards with help of the load introduction factor n : $\Phi_n = n \Phi_k$

Part A: Theory & Software Functionality

1. Refresher: Theoretical foundations of bolt analysis

Basic definitions in bolt analysis acc. to VDI 2230

Fundamental problems in bolt analysis

- One of the biggest challenges in bolt analysis is to compute this real load factor $\Phi_n = n \Phi_k$, so to estimate the n-value
- The old VDI 2230, edition 1986, used a simple image to estimate the n-value:

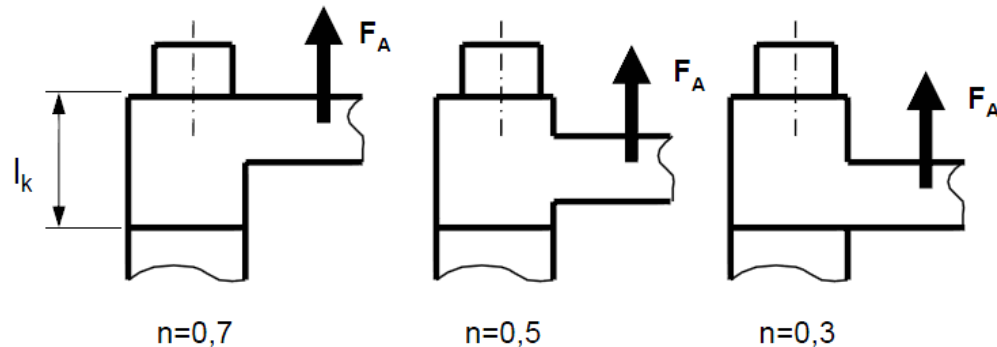

- The latest edition [1] defines 6 joint types SV1–SV6 according to type of load introduction and offers 96 accordant values in a table
- Special cases, like $n > 1$ or $\Phi_n < 0$, are not treated at all, see [3], [5]
- Even the refined VDI method is difficult to apply: A finite element analysis can help a lot, especially in case of special geometries

Part A: Theory & Software Functionality

1. Refresher: Theoretical foundations of bolt analysis

Using FEM for bolt analysis

Basic procedure to compute the real load factor Φ_n in a FEM analysis

- Run a contact analysis without operational force to adjust the required preload
 - » Note: This is an iterative procedure, since the plate resilience is not known in advance
 - » Usually, rule of three is sufficient for standard cases
 - » For strong nonlinear behavior, a Simulate sensitivity study can help
- Run a second contact analysis with the correctly adjusted preload and apply the operational load to obtain the total bolt load F_S (note: This step will be automated in Creo 3.0)
- Then, the real force relation becomes

total bolt load - preload
operational load

$$\Phi_n = (F_S - F_M) / F_A = F_{SA} / F_A$$

Part A: Theory & Software Functionality

2. Building FEM-models of bolted connections

2.1 FEM model classes according to VDI 2230 part 2

VDI 2230 part 2 (draft) proposes the following model classes:

- Model class I:
 - » The clamped parts are modeled as a continuum
 - » No bolt is in the model
 - » Resultant (cutting) loads are read out from this model
 - » With these loads, the bolt is analyzed analytically according to VDI 2230 part 1
- Model class II:
 - » The clamped parts are modeled as a continuum or with contact at the interface
 - » The bolt is idealized using a beam or spring element and connected to the bolt head or nut contact area
 - » The in this way directly obtained bolt loads can then be used for the nominal stress concept in VDI 2230 part 1

Part A: Theory & Software Functionality

2. Building FEM-models of bolted connections

2.1 FEM model classes according to VDI 2230 part 2 [2]

FEM model classes according to VDI 2230 part 2 (cont'd)

- Model class III:
 - » Here, the bolt is modeled as substitute volume body without thread
 - » By suitable geometry or material fitting it has to be assured that the substitute volume has the same resilience as the real bolt (especially regarding bolt head and threaded part resilience)
 - » Beside the contact formulation at the plate interstices, contact can also be below bolt and nut head
- Model class IV:
 - » The bolt geometry is modeled with thread and contacts at all contacting surfaces
 - » This model class allows a fully detailed view on what happens in the bolt and the connection
- With increasing model class, the limitations of VDI 2230 part 1 coming from the analytical approach fall away!

Part A: Theory & Software Functionality

2. Building FEM-models of bolted connections

2.2 Creo Simulate features suitable for these model classes

How can these model classes be realized in Simulate?

- In general, for all VDI model classes I–IV, Creo Simulate offers very suitable tools and features
- For model class I:
 - » Resultant force and moment measures
- For model class II:
 - » Fastener feature (see part A chapter 4.1)
 - » Beams
 - » Springs
- For model class III: (see part B examples)
 - » Contact interfaces
 - » Preload elements
 - » General temperature loads
- For model class IV: (see part A chapter 4.3)
 - » For extremely quick detailed analysis: Model type 2D axisymmetric

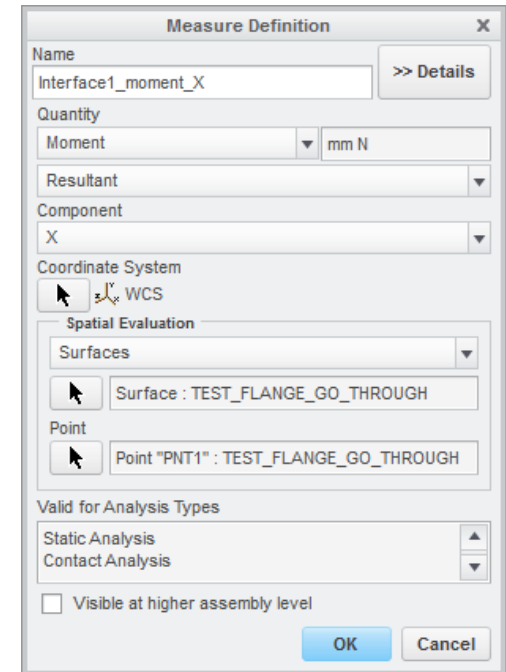
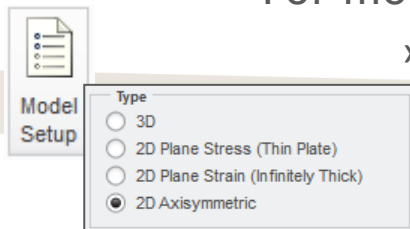
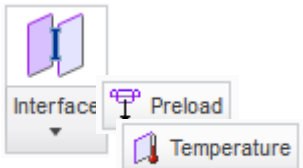
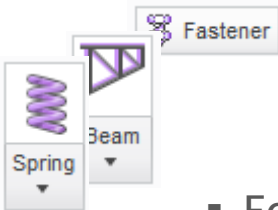
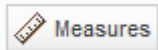

3. Linearization of bolted connections for the FEM analysis

3.1 Requirements

What do I have to take into account if I want to linearize a bolted connection?

- In general, all assumptions made in VDI 2230 part 1 and 2 should be fulfilled
- Bolted parts should be massive, prismatic bodies with high inherent rigidity. Thin sheet metal plates are NOT suitable for linearization!
- If no gapping or sliding is expected, then within the pressure cone the plates can be joined/merged
- The clamped interstices are planar (e.g. no Hertz-type contacts)

Part A: Theory & Software Functionality

3. Linearization of bolted connections for the FEM analysis

3.1 Requirements

- The bolted joint should be designed in a way that there is no difference expected between tensile and compression stiffness, e.g.:

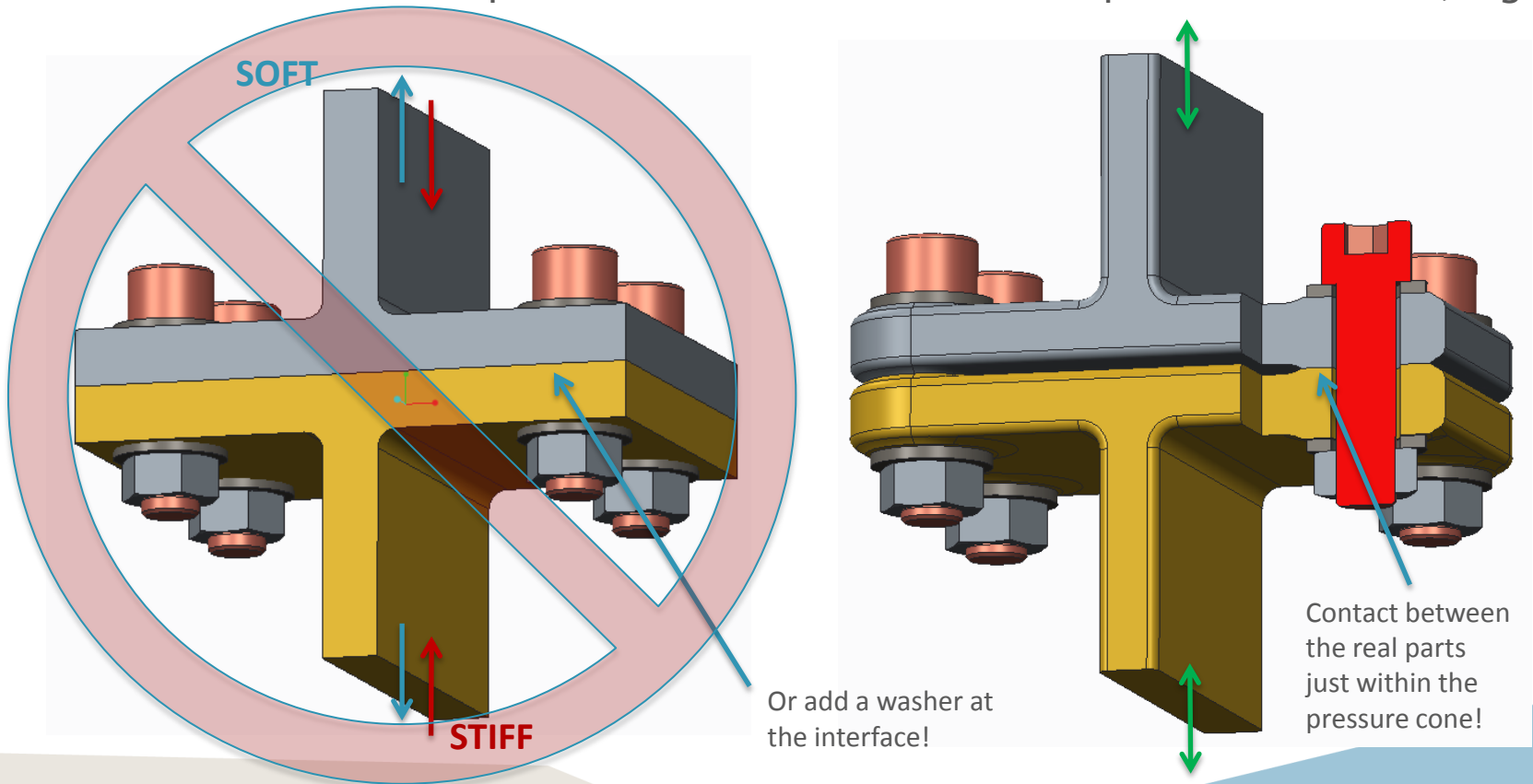

3. Linearization of bolted connections for the FEM analysis

3.2 Linear analysis without preload

Can I run linear bolt analysis without preload?

- In a linear FEM model of a bolted connection, it is possible to disregard the preload
- In this case, just one linear FEM analysis with one single load case is enough to obtain the loading and load factor of the connection!
- This can be illustrated with help of the bolt diagram:

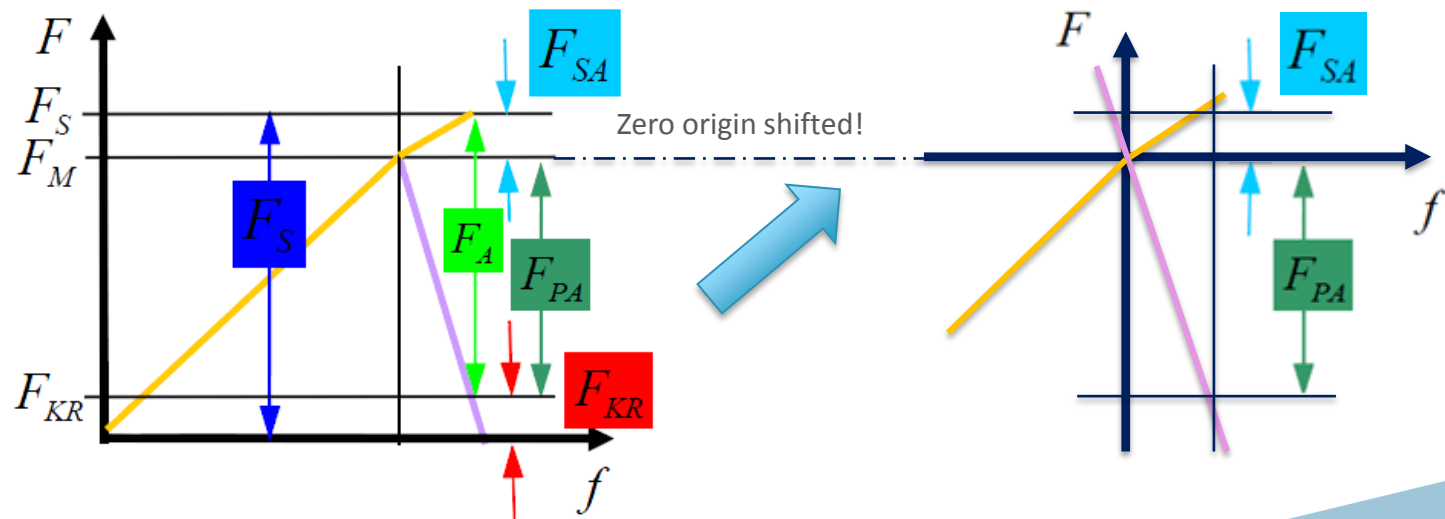

Part A: Theory & Software Functionality

3. Linearization of bolted connections for the FEM analysis

3.2 Linear analysis without preload

- Bolt additional load F_{SA} and flange unloading force F_{PA} can be read out directly by means of a resulting force measure in the bolt shaft and at the plate interface
- The individual bolted connection operational load F_A can be computed simply by adding F_{SA} and F_{PA}
- The real load factor becomes $\Phi_n = \frac{F_{SA}}{F_{SA} + F_{PA}} = \frac{F_{SA}}{F_A}$
- Then it's up to the user to select a suitable preload preventing gapping & sliding by simple analytical means!

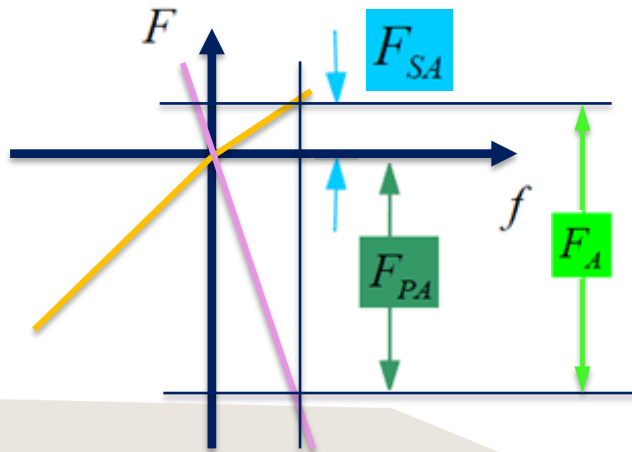

Part A: Theory & Software Functionality

4. Idealization of Bolts in Creo Simulate

4.1 The improved fastener feature since Creo Simulate 1.0

The old pre-Creo fastener feature in Mechanica Wildfire (1)

- The initial idea of this functionality was to have a tool for a quick assembly of bolted parts, giving feedback for the most essential nominal bolt loads (tensile and shear force)
- Therefore, the bolt itself was highly idealized as a pure tensile spring only, fixed with a weighted link to the bolt head and nut ring surfaces
- Shear forces were transferred by a separate spring with shear stiffness only, acting like a shear pin
- The two parts being bolted together can (and should!) have nonlinear contact in between them
- Alternatively, as a “poor man’s” linearized contact formulation, a very stiff discrete spring joined the two parts in contact
- The spring ends of this spring were connected with weighted links to the “separation test diameter” surfaces at the touching flanks

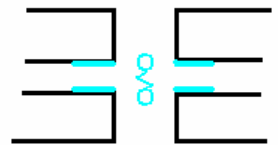
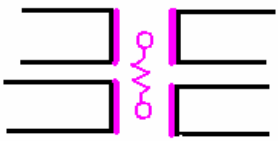
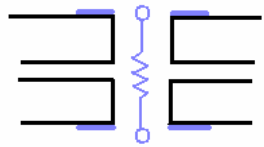

Part A: Theory & Software Functionality

4. Idealization of Bolts in Creo Simulate

4.1 The improved fastener feature since Creo Simulate 1.0

Most important limitations of the old pre-Creo fastener feature

- When used with linear separation stiffness instead of nonlinear contact, there was a high risk to underestimate the real bolted connection loadings
- This effect became bigger with thinner bolted part plates and increasing bending loads on the connection
- In addition, there was no sufficient feedback to the user to detect this case (especially bending moment measures)
- In case gapping begins, the real bolt itself may see significant bending, but the pure tensile spring used for bolt idealization could not track these loads
- Some further limitations can be taken from [4]
- The experience made with the initial feature functionality lead to a complete rework of the feature, which was then implemented in Creo Simulate 1.0

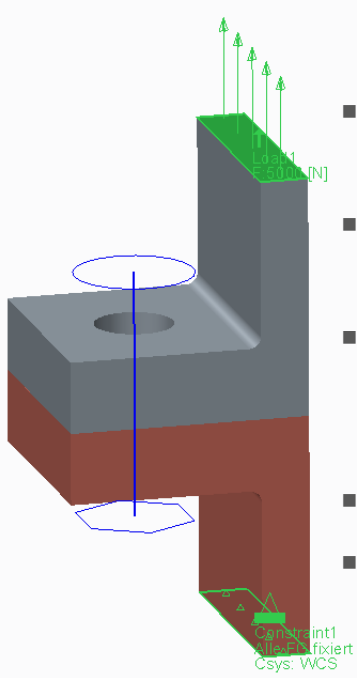

Part A: Theory & Software Functionality

4. Idealization of Bolts in Creo Simulate

4.1 The improved fastener feature since Creo Simulate 1.0

Important enhancements of the reworked Creo fastener feature (1)

- Instead of a simple tensile spring, now the bolt is idealized by a full symmetric 12x12 spring tensor that reflects a Timoshenko cylindrical beam of the specified diameter and material with the length between the selected references

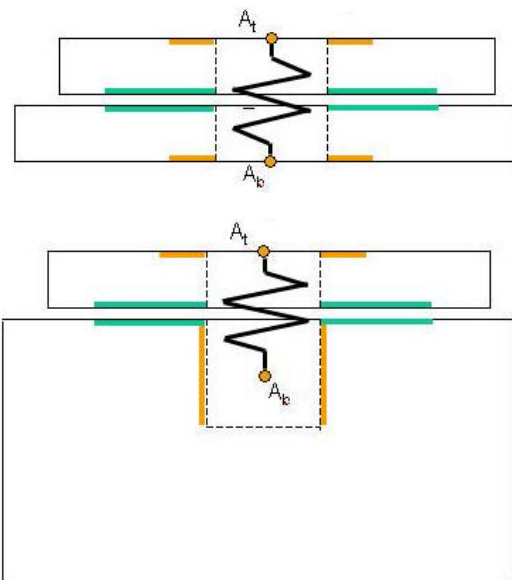

f_{1x}	EA/L	0	0	0	0	0	$-EA/L$	0	0	0	0	0	0
f_{1y}	0	$\frac{12EI_z}{(1+\phi_2)L^3}$	0	0	0	$\frac{6EI_z}{(1+\phi_2)L^2}$	0	0	$\frac{-12EI_z}{(1+\phi_2)L^3}$	0	0	0	$\frac{6EI_z}{(1+\phi_2)L^2}$
f_{1z}	0	0	$\frac{12EI_y}{(1+\phi_2)L^3}$	0	$-\frac{6EI_y}{(1+\phi_2)L^2}$	0	0	0	$\frac{-12EI_y}{(1+\phi_2)L^3}$	0	0	$-\frac{6EI_y}{(1+\phi_2)L^2}$	0
m_{1x}	0	0	0	GJ/L	0	0	0	0	0	0	$-GJ/L$	0	0
m_{1y}	0	0	$-\frac{6EI_y}{(1+\phi_2)L^2}$	0	$\frac{EI_y(4+\phi_2)}{(1+\phi_2)L}$	0	0	0	$\frac{6EI_y}{(1+\phi_2)L^2}$	0	0	$\frac{EI_y(2-\phi_2)}{(1+\phi_2)L}$	0
m_{1z}	0	$\frac{6EI_z}{(1+\phi_2)L^2}$	0	0	0	$\frac{EI_z(4+\phi_2)}{(1+\phi_2)L}$	0	$-\frac{6EI_z}{(1+\phi_2)L^2}$	0	0	0	0	$\frac{EI_z(2-\phi_2)}{(1+\phi_2)L}$
f_{2x}	$-EA/L$	0	0	0	0	0	EA/L	0	0	0	0	0	0
f_{2y}	0	$\frac{-12EI_z}{(1+\phi_2)L^3}$	0	0	0	$\frac{-6EI_z}{(1+\phi_2)L^2}$	0	$\frac{12EI_z}{(1+\phi_2)L^3}$	0	0	0	0	$\frac{-6EI_z}{(1+\phi_2)L^2}$
f_{2z}	0	0	$\frac{-12EI_y}{(1+\phi_2)L^3}$	0	$\frac{6EI_y}{(1+\phi_2)L^2}$	0	0	0	$\frac{12EI_y}{(1+\phi_2)L^3}$	0	0	$\frac{6EI_y}{(1+\phi_2)L^2}$	0
m_{2x}	0	0	0	$-GJ/L$	0	0	0	0	0	0	GJ/L	0	0
m_{2y}	0	0	$\frac{6EI_y}{(1+\phi_2)L^2}$	0	$\frac{EI_y(4+\phi_2)}{(1+\phi_2)L}$	0	0	0	$\frac{-6EI_y}{(1+\phi_2)L^2}$	0	0	$\frac{EI_y(4+\phi_2)}{(1+\phi_2)L}$	0
m_{2z}	0	$\frac{6EI_z}{(1+\phi_2)L^2}$	0	0	0	$\frac{EI_z(4+\phi_2)}{(1+\phi_2)L}$	0	$-\frac{6EI_z}{(1+\phi_2)L^2}$	0	0	0	0	$\frac{EI_z(4+\phi_2)}{(1+\phi_2)L}$

$\phi_1 = \frac{12EI_y}{EAGL^2}$ $\phi_2 = \frac{12EI_z}{KAGL^2}$

Part A: Theory & Software Functionality

4. Idealization of Bolts in Creo Simulate

4.1 The improved fastener feature since Creo Simulate 1.0

Important enhancements of the reworked Creo fastener feature (2)

- The fix separation effect of linearized fastener connections is now modeled with a stiff “distributed spring” instead of a stiff discrete spring attached by weighted links
- This distributed spring connects each point within the separation test area “very stiff” in normal direction to the same point of the opposed surface
- The effect is shown right: Interpenetrations within the separation test area are minimized

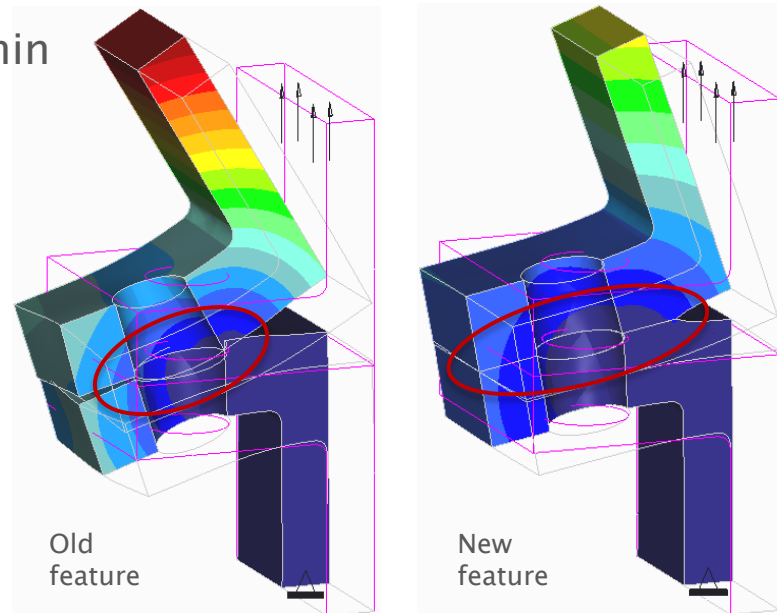

Part A: Theory & Software Functionality

4. Idealization of Bolts in Creo Simulate

4.1 The improved fastener feature since Creo Simulate 1.0

Important enhancements of the reworked Creo fastener feature (3)

- The new distributed spring therefore also significantly stiffens the connected regions (they stay more planar) and so may create a stress singularity at the separation test area border
- This distributed spring can also transfer the lateral force where it is transferred in reality by friction: Over the clamped flange flanks, not over the bolt (holes) acting as a shear pin
- This happens with “Frictionless Interface”=off, then a stiff shear component is activated within the distributed spring

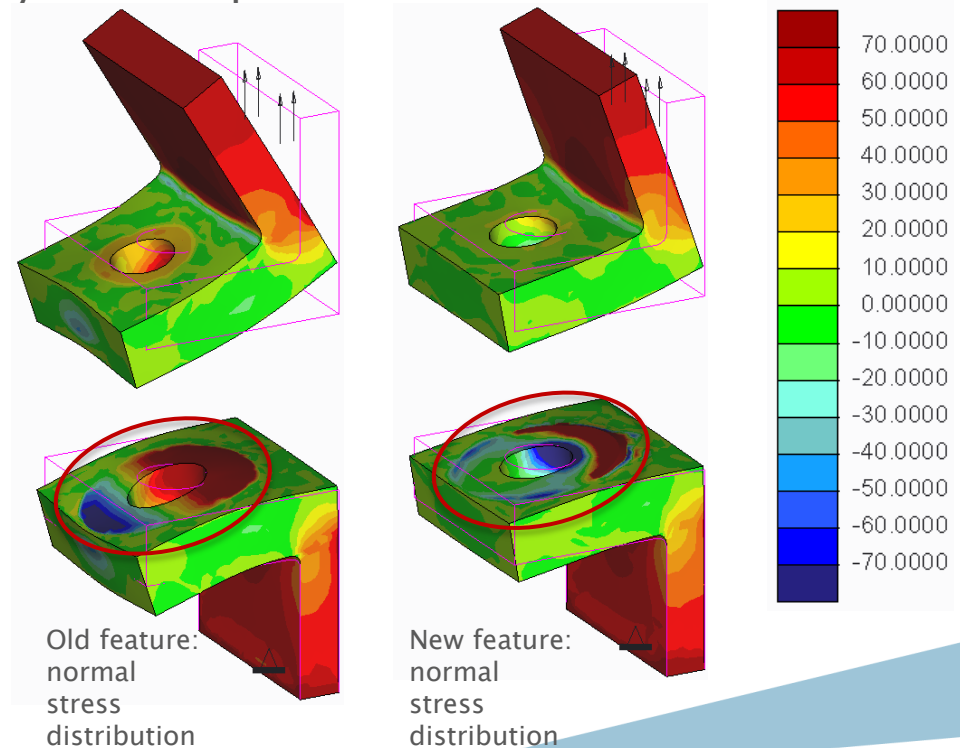

Part A: Theory & Software Functionality

4. Idealization of Bolts in Creo Simulate

4.1 The improved fastener feature since Creo Simulate 1.0

Important enhancements of the reworked Creo fastener feature (4)

- There is now full measure output of all quantities for the fastener itself, e.g.:

```
Fastener1_axial_force:      -4.640253e+02
Fastener1_axial_stress:    -1.641154e+01
Fastener1_bending_moment:  2.537936e+02
Fastener1_bending_stress:  1.196815e+01
Fastener1_shear_force:     1.114407e-10
Fastener1_shear_stress:    3.941410e-12
Fastener1_torsion_moment:  -3.400345e-09
Fastener1_torsion_stress:  -8.017507e-11
```

- When used with linear separation stiffness, there is an additional complete measure output for all quantities transferred by the clamped flanks, e.g.

```
Fastener1_intf_bend_momt:  1.892819e-02
Fastener1_intf_norm_forc:  3.871658e-03
Fastener1_intf_shr_forc:   7.949143e-03
Fastener1_intf_tors_momt:  9.845679e+03
Fastener1_sep_stress:      1.338186e-02
```

- This allows e.g. to identify critical bending loads on the bolted connection without using the time-consuming contact model

Part A: Theory & Software Functionality

4. Idealization of Bolts in Creo Simulate

4.1 The improved fastener feature since Creo Simulate 1.0

Important enhancements of the reworked Creo fastener feature (5)

- New, improved UI; separates between fasteners connecting solids or fasteners connecting shells
- Only those options are visible that make sense in the current definition context
- Finally, error messages and warnings have been improved (enhanced user feedback)

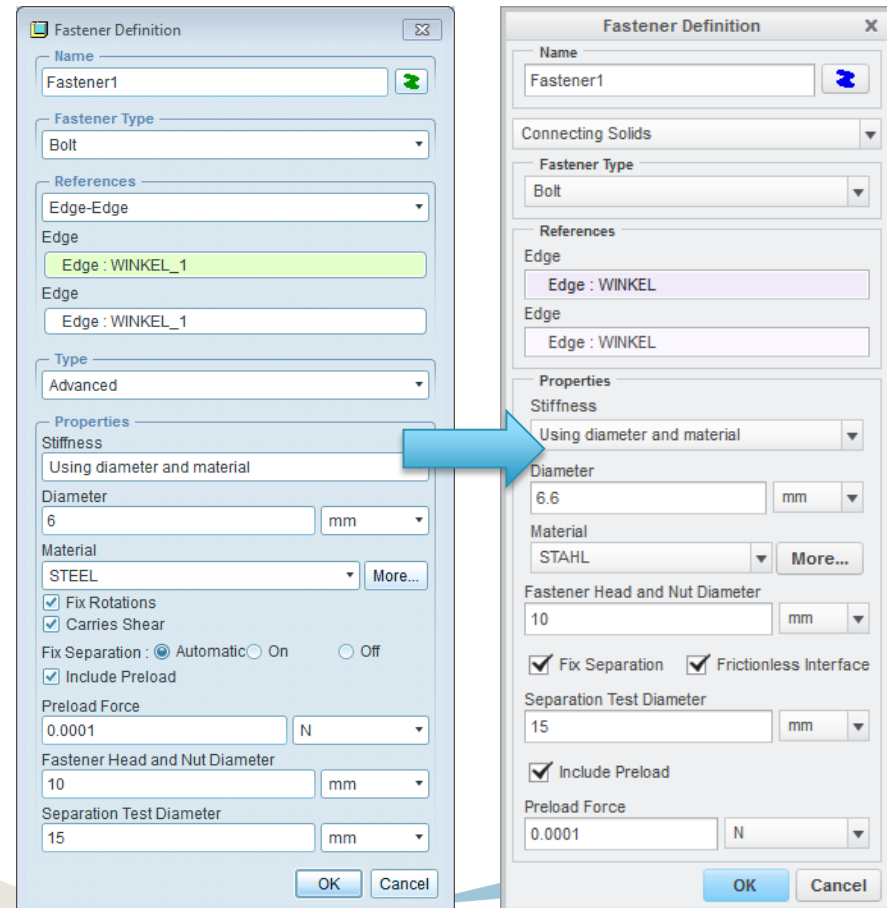

Part A: Theory & Software Functionality

4. Idealization of Bolts in Creo Simulate

4.1 The improved fastener feature since Creo Simulate 1.0

Functionality brief of the new fastener feature

Fasteners connecting shells (1)

- In this case, the functionality is very close to the old fastener feature: No distributed spring is used for the shell surfaces connection (unlike in fasteners connecting solids!)
- Instead over the old 6x6 spring matrix, all forces are now transferred over the full 12x12 spring matrix (“Using diameter and material”)
- The spring ends are connected with weighted links to the head and nut diameters
- “Edge–Edge” or “Point–Point” references may be used for fasteners connecting shells
- Note for shell elements, it does not make sense (and it is therefore not supported) to work with preloads: This is a very high–level idealization only!

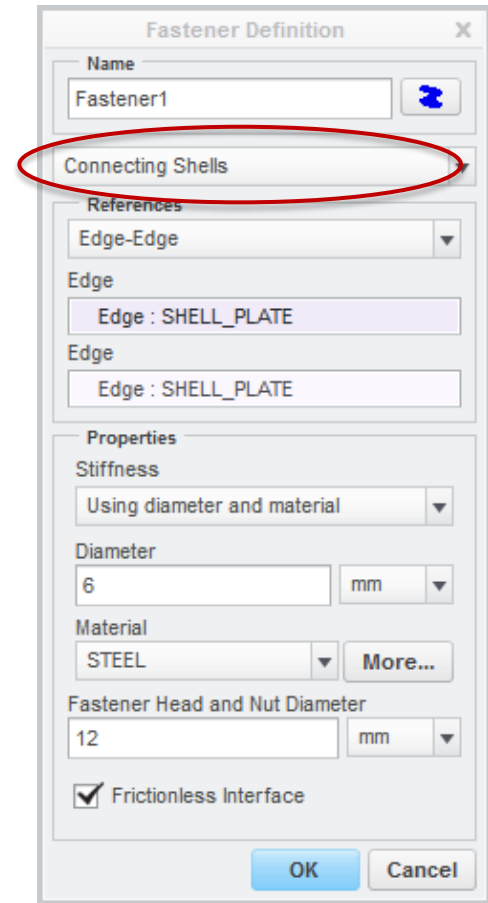
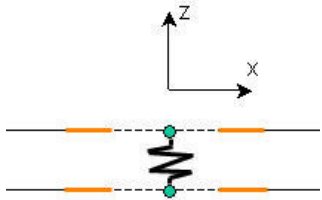

Part A: Theory & Software Functionality

4. Idealization of Bolts in Creo Simulate

4.1 The improved fastener feature since Creo Simulate 1.0

Functionality brief of the new fastener feature Fasteners connecting shells (2)

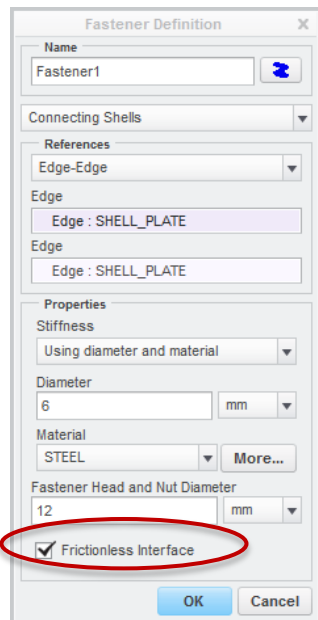
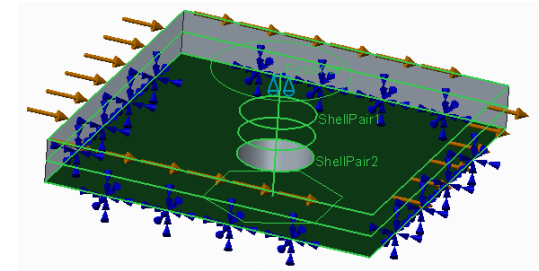

- In case of “Frictionless Interface”=on, full measure output is provided for the quantities transferred over the idealized fastener:

Fastener1_axial_force:	5.642041e-13
Fastener1_axial_stress:	1.995464e-14
Fastener1_bending_moment:	1.000000e+03
Fastener1_bending_stress:	4.715702e+01
Fastener1_shear_force:	1.000000e+03
Fastener1_shear_stress:	3.536777e+01
Fastener1_torsion_moment:	2.503637e-11
Fastener1_torsion_stress:	5.903203e-13

- The connection is shear-soft in this case:
Note if frictionless interface=on, the spring stiffness matrix will be set as calculated “Using material and diameter” (12x12 matrix) or specified by the user “Using spring stiffness property” (6x6 matrix)

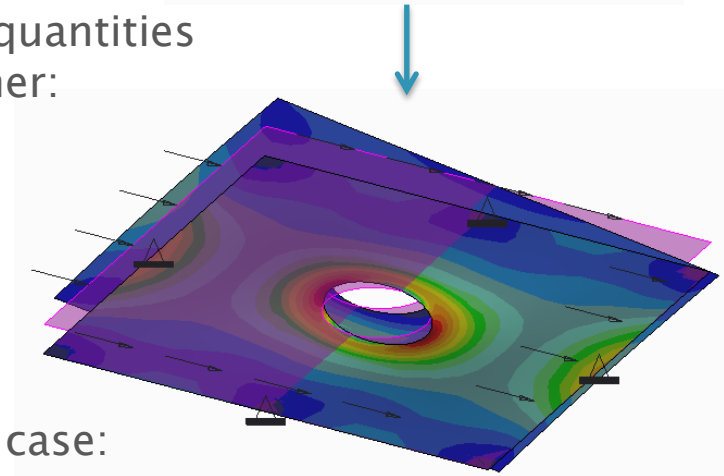

Part A: Theory & Software Functionality

4. Idealization of Bolts in Creo Simulate

4.1 The improved fastener feature since Creo Simulate 1.0

Functionality brief of the new fastener feature Fasteners connecting shells (3)

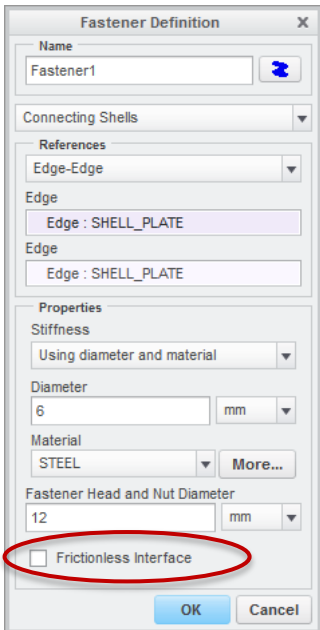
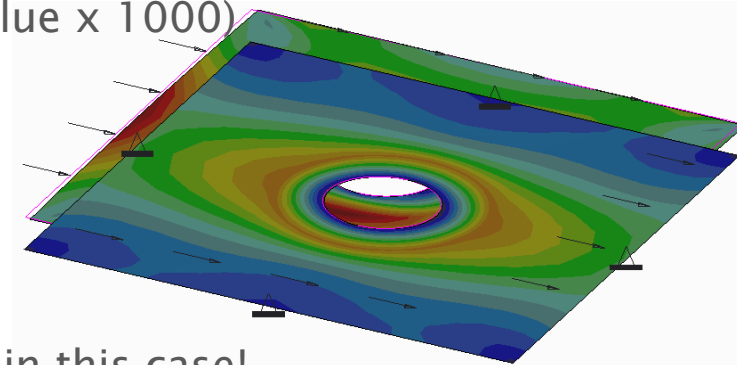
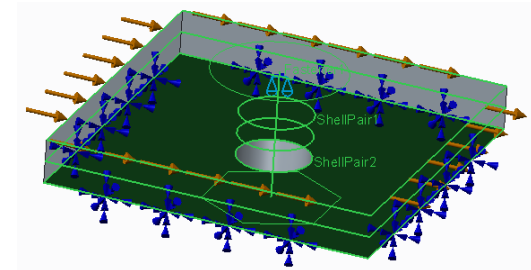

- In case of “Frictionless Interface”=off, the diagonal terms 2-2, 3-3, 4-4, 8-8, 9-9 and 10-10 and coupling terms 8-2, 9-3, 10-4, 2-8, 3-9, 4-10, of the 12x12 spring stiffness matrix are replaced with a large number (value x 1000)

- Measure output is reduced to axial force and bending moment only:

Fastener1_axial_force: 1.155386e-14
Fastener1_axial_stress: 4.086343e-16
Fastener1_bending_moment: 1.692832e-01
Fastener1_bending_stress: 7.982892e-03

- The connection becomes shear-stiff in this case!
- Note the checkboxes “Carries Shear” and “Fix Rotations” of the old feature version are not any longer available, they are replaced by the “Frictionless Interface” option!

Part A: Theory & Software Functionality

4. Idealization of Bolts in Creo Simulate

4.1 The improved fastener feature since Creo Simulate 1.0

Functionality brief of the new fastener feature

Fasteners connecting solids (1)

- For fasteners connecting solids, only edge references may be selected, type is bolt or screw (no points option like in the pre-Creo version)

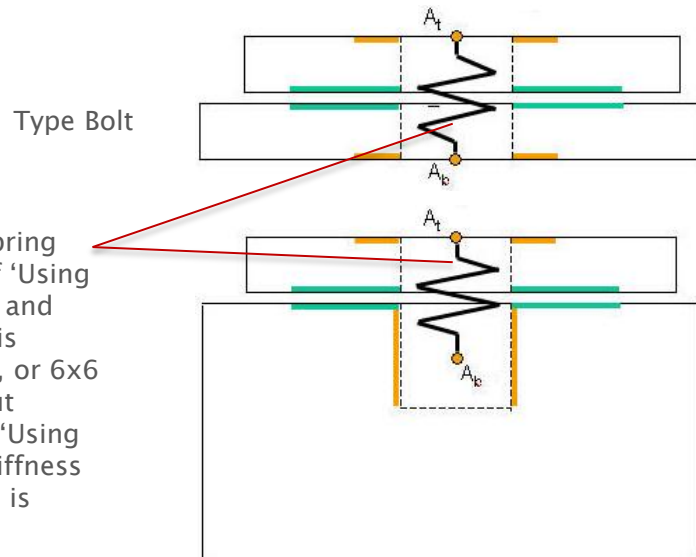

Type Screw

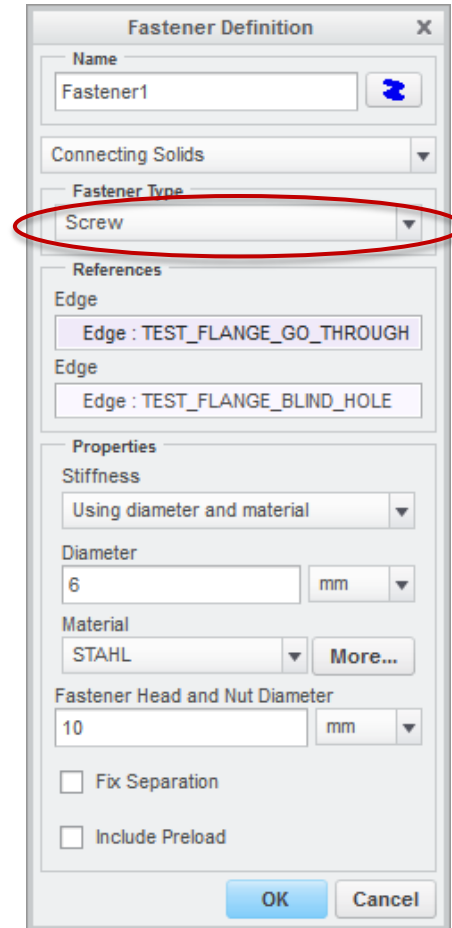
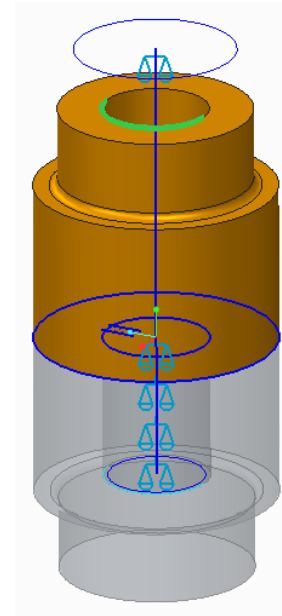

Part A: Theory & Software Functionality

4. Idealization of Bolts in Creo Simulate

4.1 The improved fastener feature since Creo Simulate 1.0

Functionality brief of the new fastener feature

Fasteners connecting solids (2)

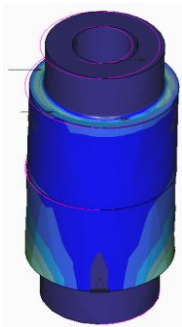

Frictionless Interface off

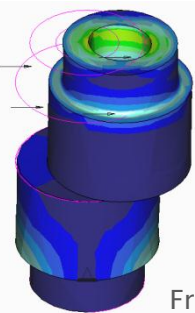

Frictionless Interface on

- With “Fix Separation”, the user can manually activate the linear distributed spring; then the field to enter the separation test diameter becomes visible (this is ignored in case of a contact interface in a contact analysis)
- By default, this spring has a high tangential stiffness to transfer shear loads (“Frictionless Interface”=off): The idea is to simulate friction between the clamped and preloaded flanks
- Note “Frictionless Interface” does not control the bolt spring matrix like in fasteners connecting shells, but toggles the high tangential stiffness value of the distributed spring at the interstice!

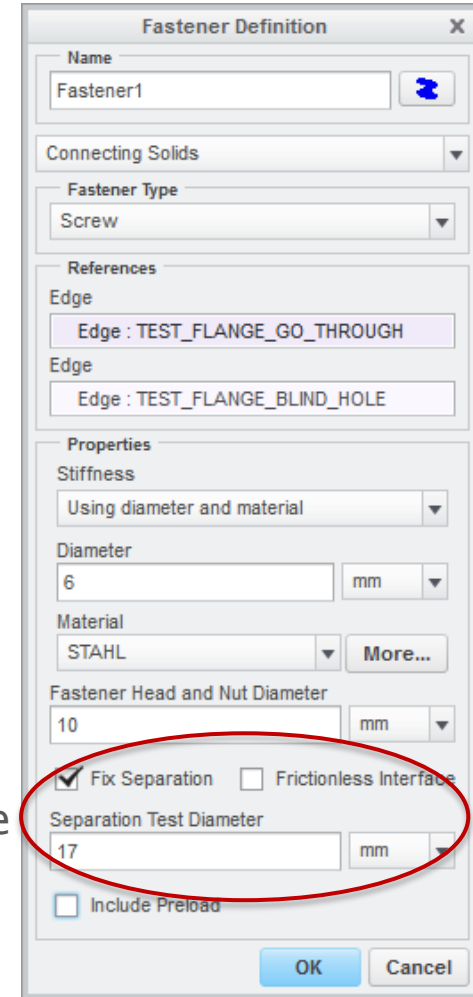

Part A: Theory & Software Functionality

4. Idealization of Bolts in Creo Simulate

4.1 The improved fastener feature since Creo Simulate 1.0

Functionality brief of the new fastener feature

Fasteners connecting solids (3)

- Even without entering a preload, a full measure data set is provided to judge about bolt and interface loading:

Fastener Loads	Fastener1_axial_force:	1.203388e-02
	Fastener1_axial_stress:	4.256113e-04
	Fastener1_bending_moment:	1.678083e+01
	Fastener1_bending_stress:	7.913341e-01
Linear interface measures (distributed spring loads)	Fastener1_intf_bend_momt:	9.751562e+02
	Fastener1_intf_norm_forc:	-1.203380e-02
	Fastener1_intf_shr_forc:	1.536787e+00
	Fastener1_intf_tors_momt:	2.495677e-03
	Fastener1_sep_stress:	1.474746e+00
	Fastener1_shear_force:	1.536787e+00
	Fastener1_shear_stress:	5.435273e-02
	Fastener1_torsion_moment:	-2.485497e-03
	Fastener1_torsion_stress:	-5.860431e-05

- This is very useful for linear analysis and required in a dynamic analysis, which per default is linear in Simulate, since all dynamic analyses are based on a modal formulation!

Fastener Definition

Name: Fastener1

Connecting Solids: [Dropdown]

Fastener Type: Screw

References

Edge: Edge : TEST_FLANGE_GO_THROUGH

Edge: Edge : TEST_FLANGE_BLIND_HOLE

Properties

Stiffness: Using diameter and material

Diameter: 6 mm

Material: STAHL

Fastener Head and Nut Diameter: 10 mm

Fix Separation Frictionless Interface

Separation Test Diameter: 17 mm

Include Preload

Preload Force: 0 N

OK Cancel

Part A: Theory & Software Functionality

4. Idealization of Bolts in Creo Simulate

4.1 The improved fastener feature since Creo Simulate 1.0

Functionality brief of the new fastener feature

Fasteners connecting solids (4)

Fastener1_sep_stress:	1.474746e+00
-----------------------	--------------

- Note in the pre-Creo fastener feature version, the “fastener_separation_stress”-measure was defined as follows:
$$\frac{\text{fix separation spring normal force}}{\text{fastener cross section}}$$
- Experienced users used this measure to obtain the normal force transferred by the bolted flange interface, since no direct measure output was provided
- Note now the interface normal force is output directly as measure “Fastener1_intf_norm_forc”
- The “Fastener1_sep_stress” measure definition has been changed now, it is just thought as a control quantity to check how close the system is to gapping
- For pure tension (centric loading), this quantity becomes
$$\frac{\text{distributed spring normal force}}{\text{fix separation test cross section}}$$

Part A: Theory & Software Functionality

4. Idealization of Bolts in Creo Simulate

4.1 The improved fastener feature since Creo Simulate 1.0

Functionality brief of the new fastener feature

Fasteners connecting solids (5)

- When a fastener is used with a contact interface in a contact analysis, the contact interface defines how the interface behaves (friction-free or with infinite friction)
- In this case, the contact interface measures output the interface loading, so use consistent contact interface names for tracking!

Fastener
Loads

```
Fastener1_axial_force:      7.381490e+03
Fastener1_axial_stress:    2.157577e+02
Fastener1_bending_moment:  1.653843e+02
Fastener1_bending_stress:  5.859529e+00
Fastener1_shear_force:     5.360662e+01
Fastener1_shear_stress:    1.566898e+00
Fastener1_torsion_moment:  1.665624e-02
Fastener1_torsion_stress:  2.950634e-04
```

Contact interface
loads (example
with infinite
friction)

```
Interface1_any_slippage:   1.383676e+01
Interface1_area:          1.423634e+02
Interface1_average_slippage: 3.062111e+00
Interface1_complete_slippage: -1.204043e+01
Interface1_force:         7.441912e+03
Interface1_force_X:       9.463934e+02
Interface1_force_Y:       -7.381490e+03
Interface1_force_Z:       -2.777106e-02
Interface1_max_tang_traction: 3.370646e+01
```

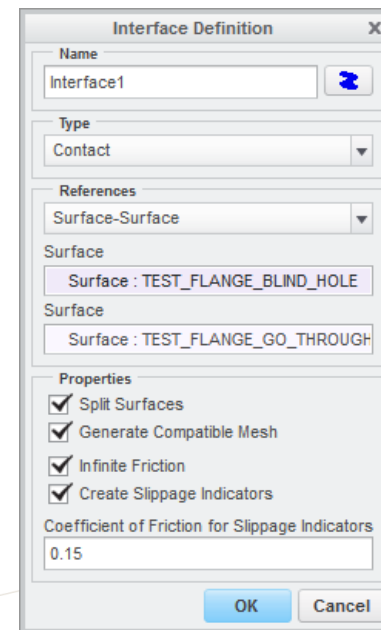

Part A: Theory & Software Functionality

4. Idealization of Bolts in Creo Simulate

4.2 Pretension elements

Pretension elements

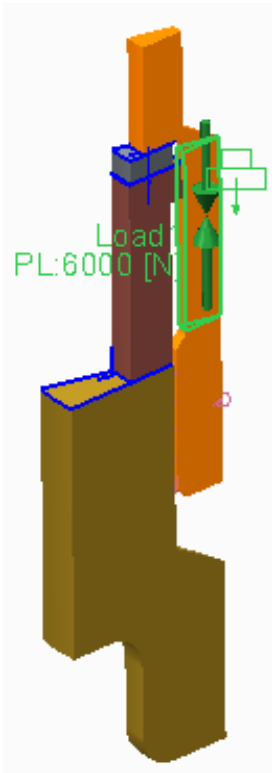

- Pretension elements allow to preload a complete solid component or just a volume region within a component in a certain direction
- The preload is part of a load set and can be time dependently controlled in a nonlinear analysis
- In a linear analysis, the preload can be linear superposed to any other load case within the post processor
- Note the preload is not adjusted automatically; usually a lower preload is obtained after the analysis!
- If required, therefore a second analysis must be performed with an adjusted preload (usually rule of three is sufficient for planar contact surfaces)

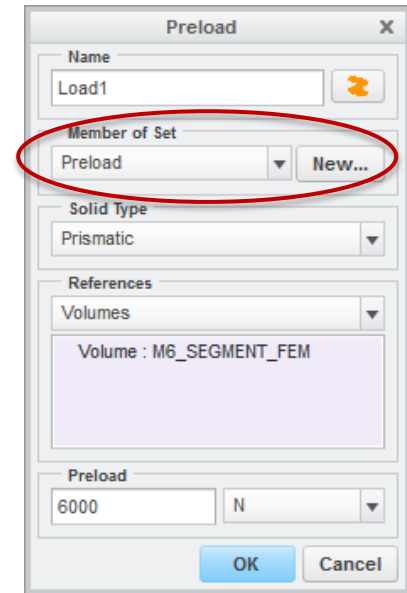

Part A: Theory & Software Functionality

4. Idealization of Bolts in Creo Simulate

4.2 Pretension elements

How do pretension elements work?

- Internally, the preload is obtained by thermal shrinking of the volume
- Note even though it is not necessary that the material assigned to the volume must have a non-Zero CTE (α) – a “virtual” CTE is used
- Three well-known equations for understanding:

$$F = K \cdot \Delta l$$

$$K = \frac{EA}{l}$$

$$\Delta l = l \cdot \alpha \cdot \Delta T$$

- When the user requests a certain preload, then the preloaded volume is “assembled to an amount Δl to short” that would create this preload F
- Since the clamped parts are flexible, the volume is not elongated to the full length Δl that would have created this preload

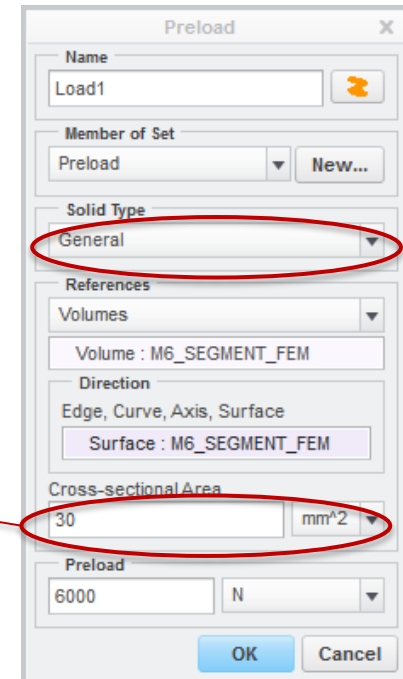

Part A: Theory & Software Functionality

4. Idealization of Bolts in Creo Simulate

4.3 More methods of idealization

What other tools do I have to model bolts in Simulate?

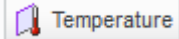
- In addition to the previously described special features, Simulate of course offers the same idealized elements like other FEM codes, which are:
 - » Beam elements
 - » Discrete springs
 - » Shells (to idealize the bolt head if a beam is used for the bolt)
 - » Volumes (e.g. for the complete bolt or just the bolt head)
 - » Weighted links (like NASTRAN RBE3)
 - » Rigid links (like NASTRAN RBE2)
- Note for creating preloads, also the new Creo generalized global temperature load can be used, which allows to apply a ΔT just for a certain reference, not only the complete model like in previous releases! 

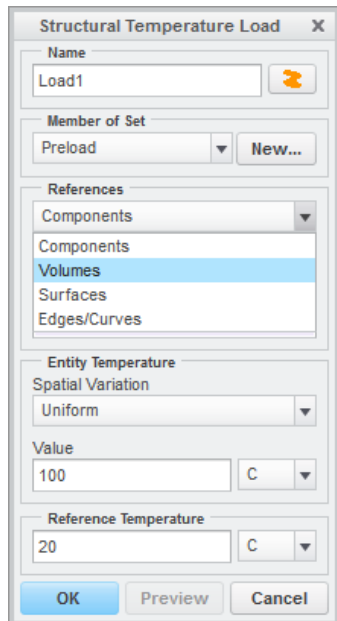

Part A: Theory & Software Functionality

4. Idealization of Bolts in Creo Simulate

4.3 More methods of idealization

- Furthermore, axial symmetric bolted connections can be idealized as 2D axial symmetric model including contact
- 2D axial symmetric models offer a very high analysis speed, so detailed models with contact, containing all threaded flanks, can be computed in a few seconds or minutes of time
- For examples see [5] or look into the SAXSIM archive of PTC/DENC presentations, e.g. [3], [6]

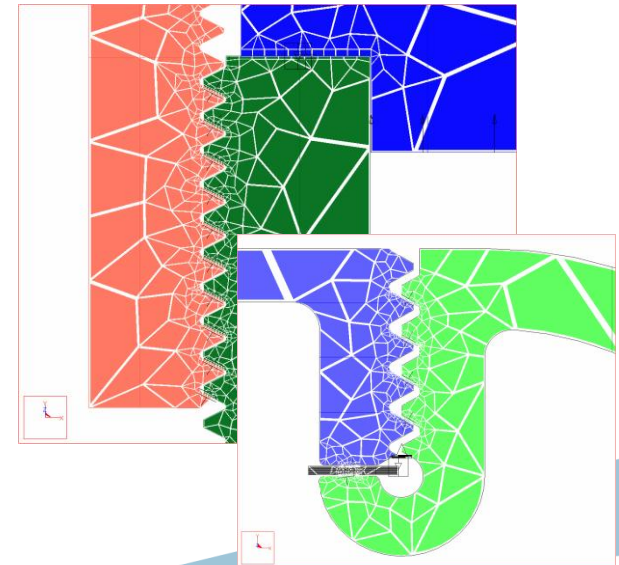
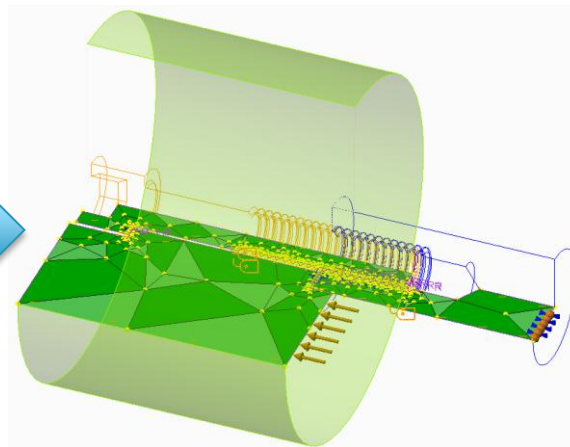
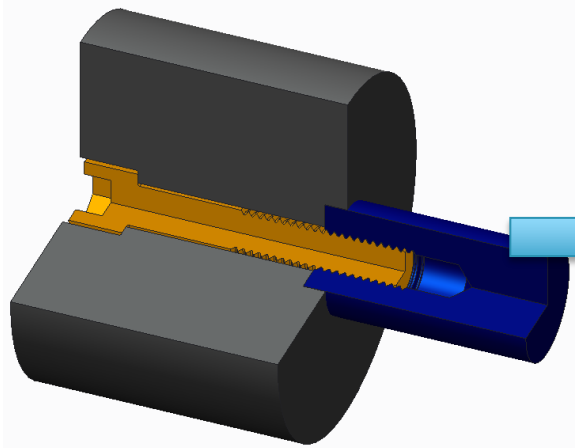

Part A - Theory & Software Functionality

4. Idealization of Bolts in Creo Simulate

4.4 Current software limitations

What are the current limits in Simulate when analyzing bolts in Large Displacement Analysis (LDA)?

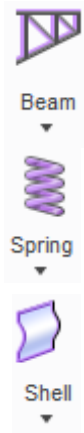

- Several idealized elements do not support large rotations, like:

- » Beam elements
- » Advanced or to ground discrete springs (simple springs do!)
- » Shells
- » Weighted links
- » Advanced rigid links (simple rigid links do!)
(state Creo 2 M040)

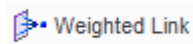

- As consequence, these elements are either not allowed to be in the model at all (beams, shells, advanced and to-ground springs) or close to them the rotations must stay small (weighted and advanced rigid links)



Part A - Theory & Software Functionality

4. Idealization of Bolts in Creo Simulate

4.4 Current software limitations

What are the current limits in Simulate when analyzing bolts with elasto-plasticity?

- In analyses containing elasto-plastic materials, also some other things have to be taken into account:

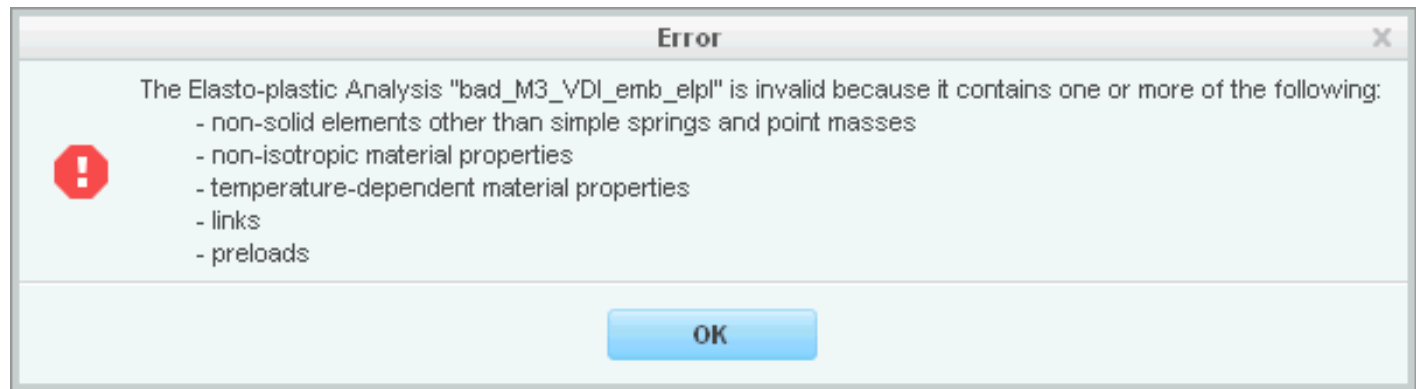

- However, some workarounds often allow to analyze such problems even though, see application example 1 of part B

Part B: Advanced Application Examples

1. Bolts with elasto-plasticity and complex load history (tightening, embedding)
2. Additional fastener loadings because of thin flanges and eccentric load introduction

Part B: Advanced Application Examples

1. Bolts with elasto-plasticity and complex load history (tightening, embedding)

Application example

- Given flange interface containing six hexagon socket screws M3x12
- The bolts had an undetected manufacturing flaw: The hexagon socket (Inbus) was created too deep and weakened the bolt head
- During assembly, these bolts were tightened by a torque tool
- Those that broke during tightening were replaced with other bolts (also containing possible flaws), then the system went into service
- The question was: Does this interface work reliable or do all bolts have to be replaced immediately?

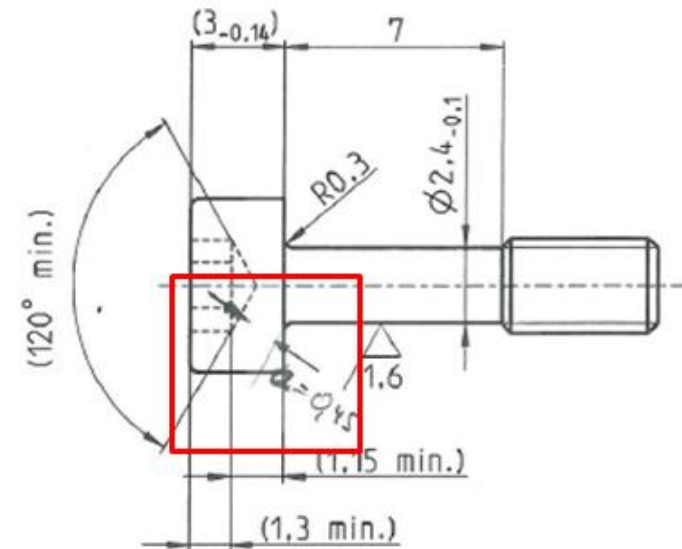

Part B: Advanced Application Examples

1. Bolts with elasto-plasticity and complex load history (tightening, embedding)

Procedure for strength proof

- The only reliable quality assurance was that all bolts which went into service withstood the tightening torque without rupture
- It was well possible that several bolts were loaded above their yield limit during tightening
- There are only two possible helpful effects which could help that subsequent additional operational loads do not lead to failure:
 - » Preload loss due to embedding
 - » Removal/loss of tightening torque/stress
- Consequently, it has to be shown that the tightening loads and embedding effects cover later operational loads
- As consequence, a nonlinear model had to be set-up, taking into account
 - » Elasto-plasticity [7]
 - » Detailed fastener geometry and bolt head contact
 - » Load history

Part B: Advanced Application Examples

1. Bolts with elasto-plasticity and complex load history (tightening, embedding)

Model set-up

- A small 15°-segment cut out from the flange was created
- The fastener was represented with volume, but without detailed thread (= model class III acc. to VDI 2230 part 2)
- The used model features were carefully selected in order to allow an analysis with elasto-plasticity (to prevent to run into the described current software limitations)

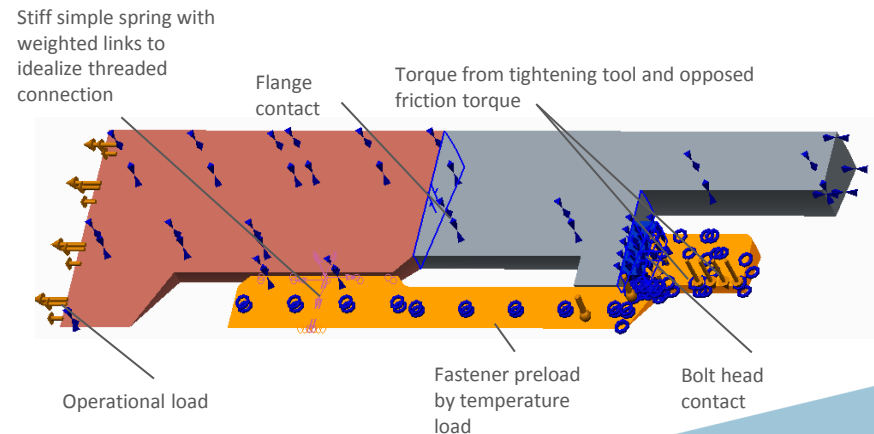
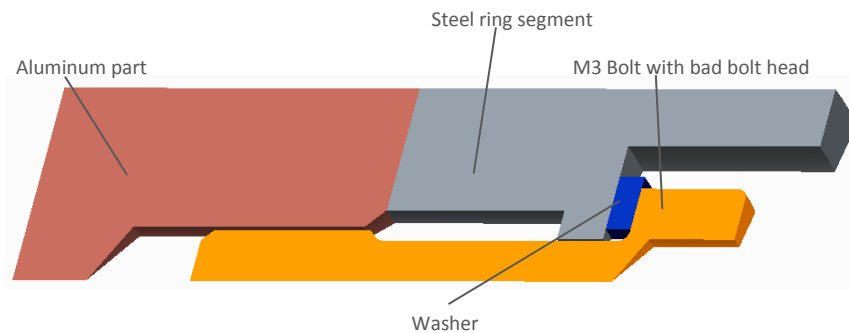

Part B: Advanced Application Examples

1. Bolts with elasto-plasticity and complex load history (tightening, embedding)

Material

- Linear hardening material law was selected (yield limit 900 MPa)

Load Stepping (tabular time functions in nonlinear LDA):

- Step 0: No loads, Zero (contact) fit everywhere
- Step 1: Bolt preload, tightening torque and opposed acting bolt head friction torque applied
- Step 2: Embedding (preload loss applied by axial washer shrinking)
- Step 3: Removing tightening torque
- Step 4: Adding operational tensile load

Part B: Advanced Application Examples

1. Bolts with elasto-plasticity and complex load history (tightening, embedding)

Stress results step 0: No load

Note finer legend stepping above yield stress (900 MPa)!

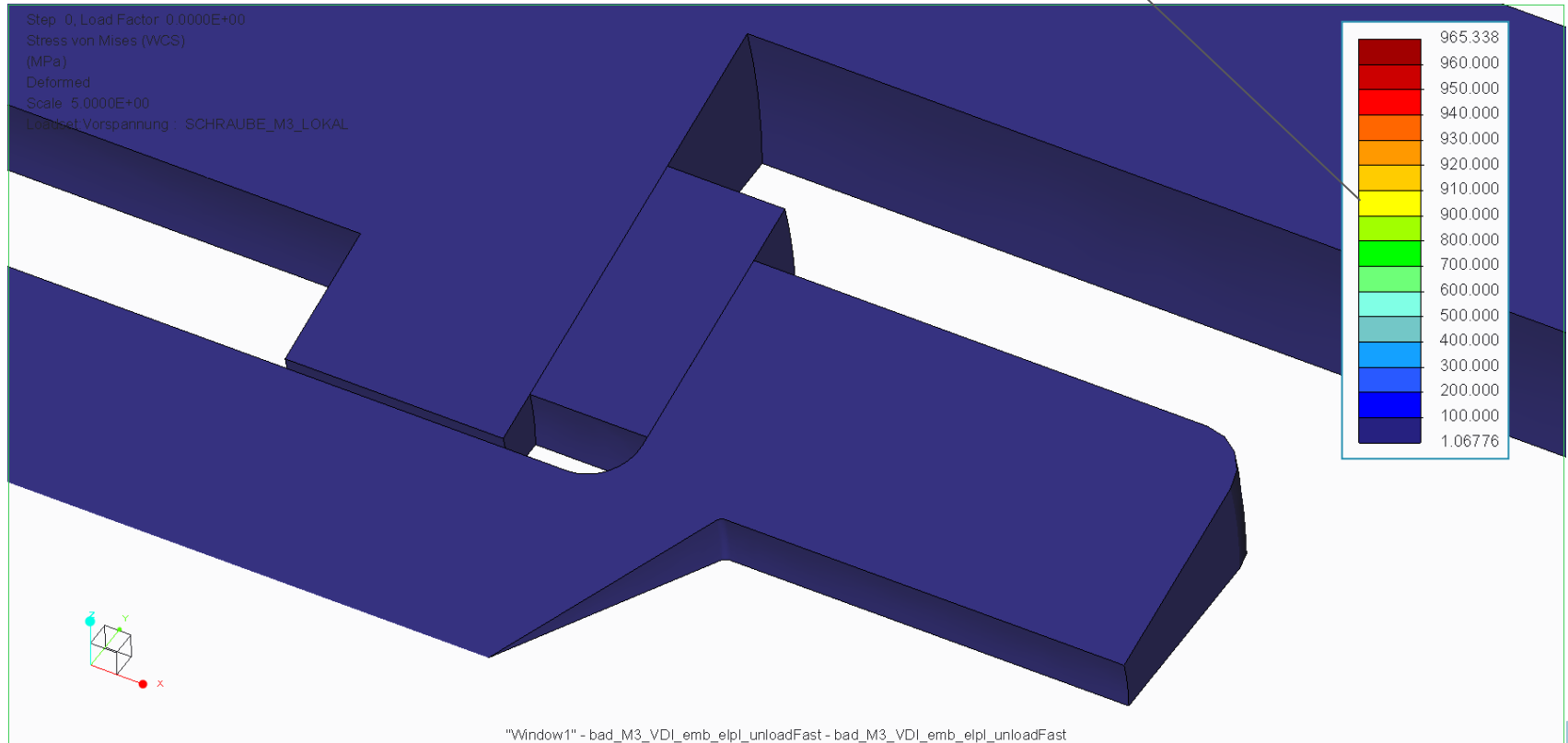

Part B: Advanced Application Examples

1. Bolts with elasto-plasticity and complex load history (tightening, embedding)

Stress results step 1: Preload and tightening torque

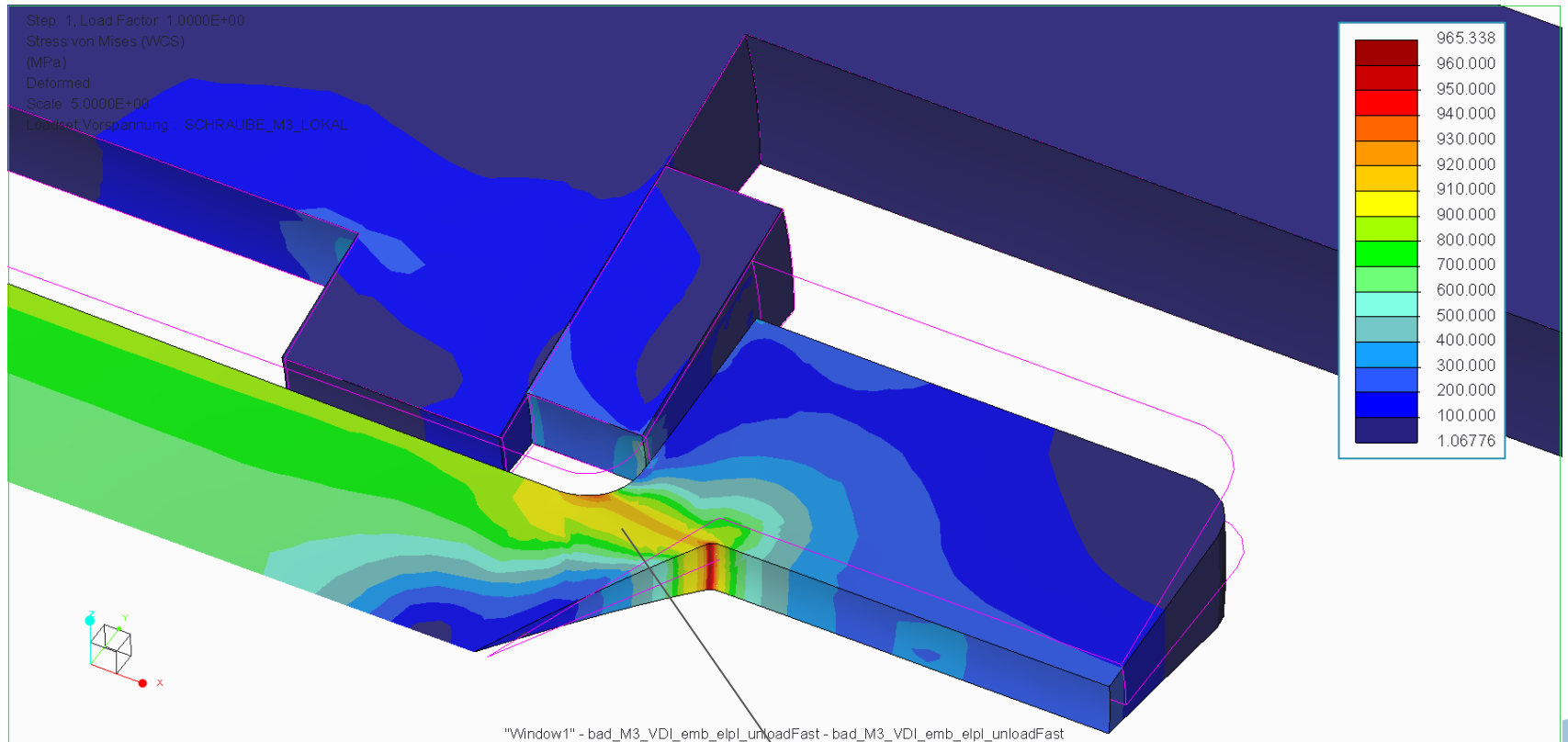

Complete critical cross section is significantly loaded above yield stress (yellow)

Part B: Advanced Application Examples

1. Bolts with elasto-plasticity and complex load history (tightening, embedding)

Stress results step 2: Embedding

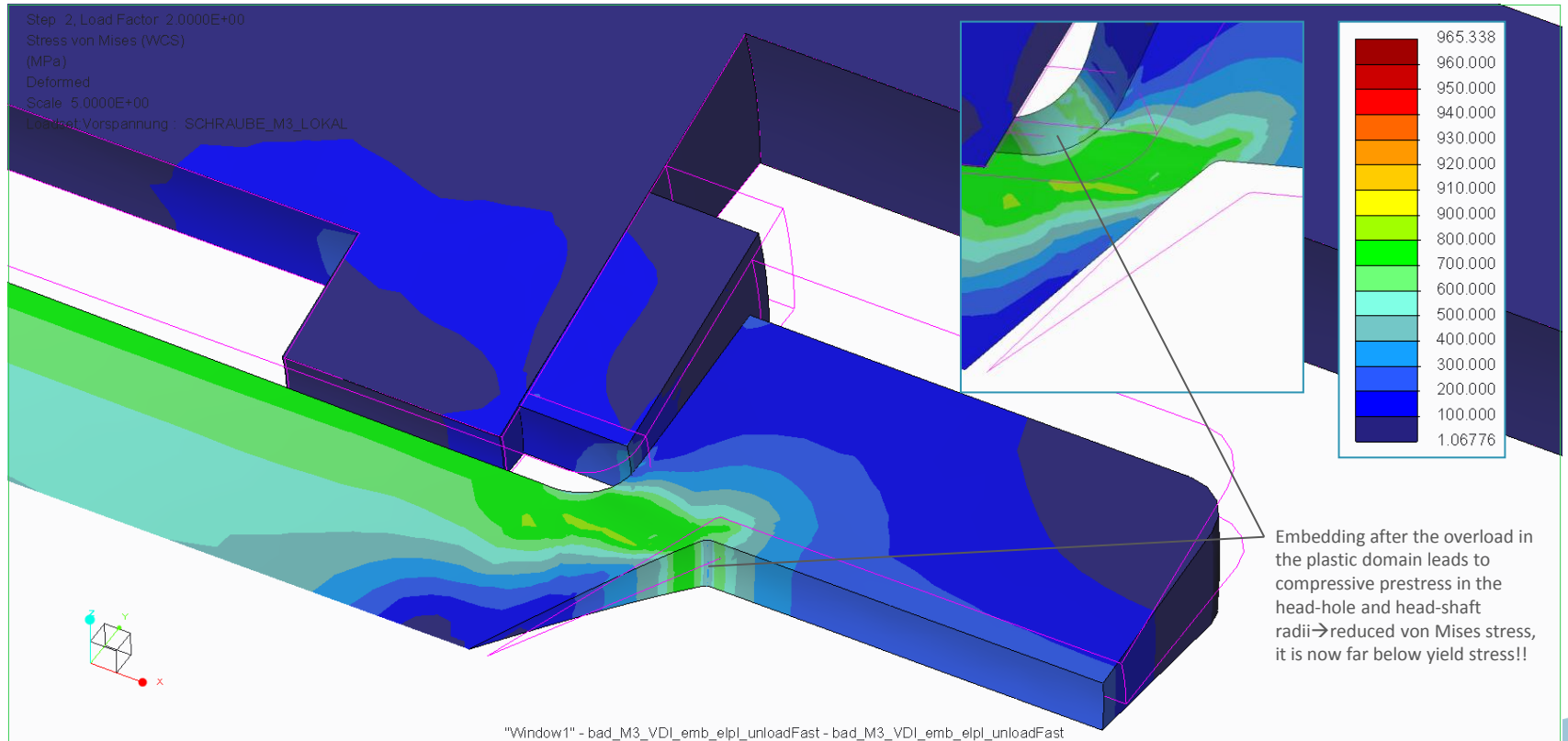

Part B: Advanced Application Examples

1. Bolts with elasto-plasticity and complex load history (tightening, embedding)

Stress results step 3: Removed tightening torque

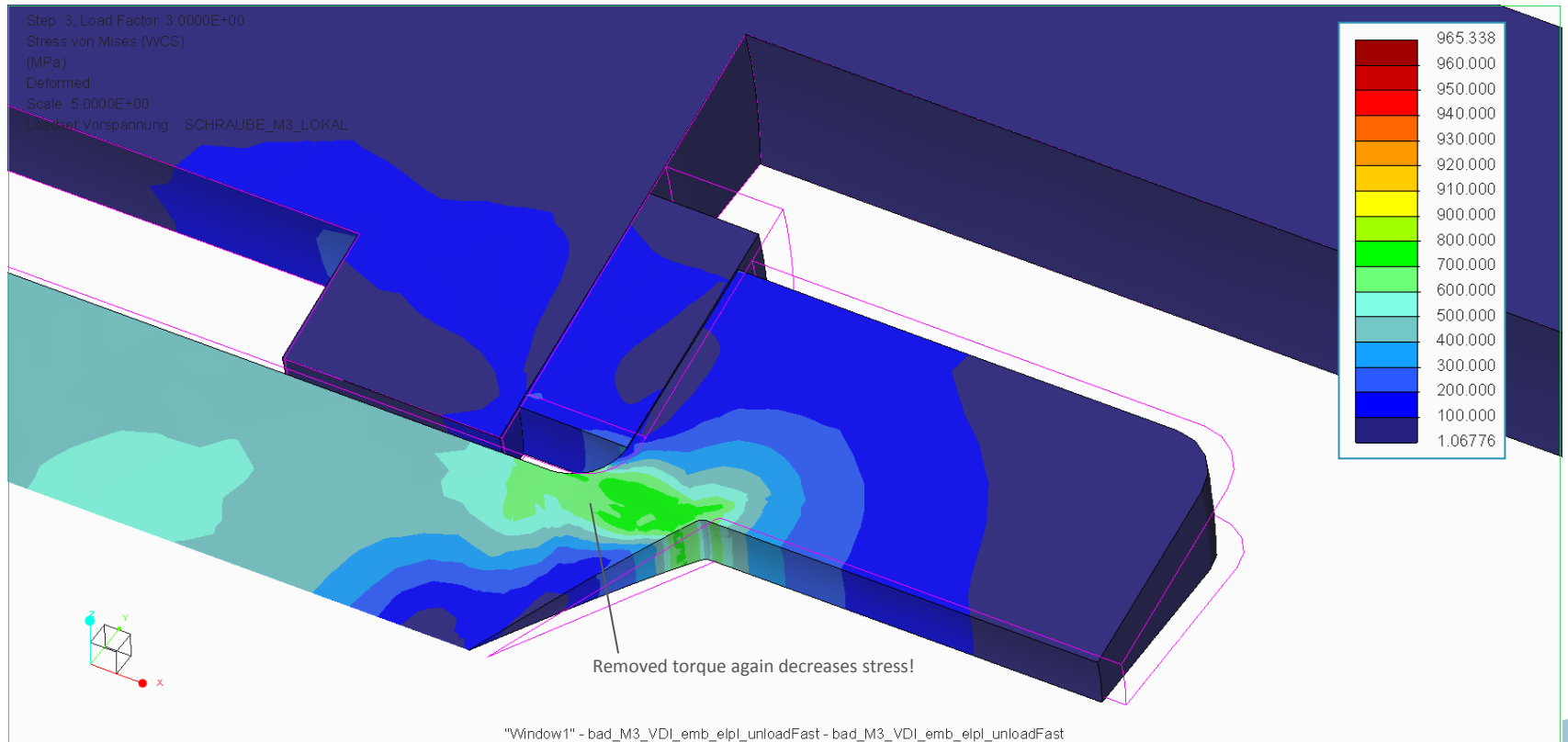

Part B: Advanced Application Examples

1. Bolts with elasto-plasticity and complex load history (tightening, embedding)

Stress results step 4: Operational load

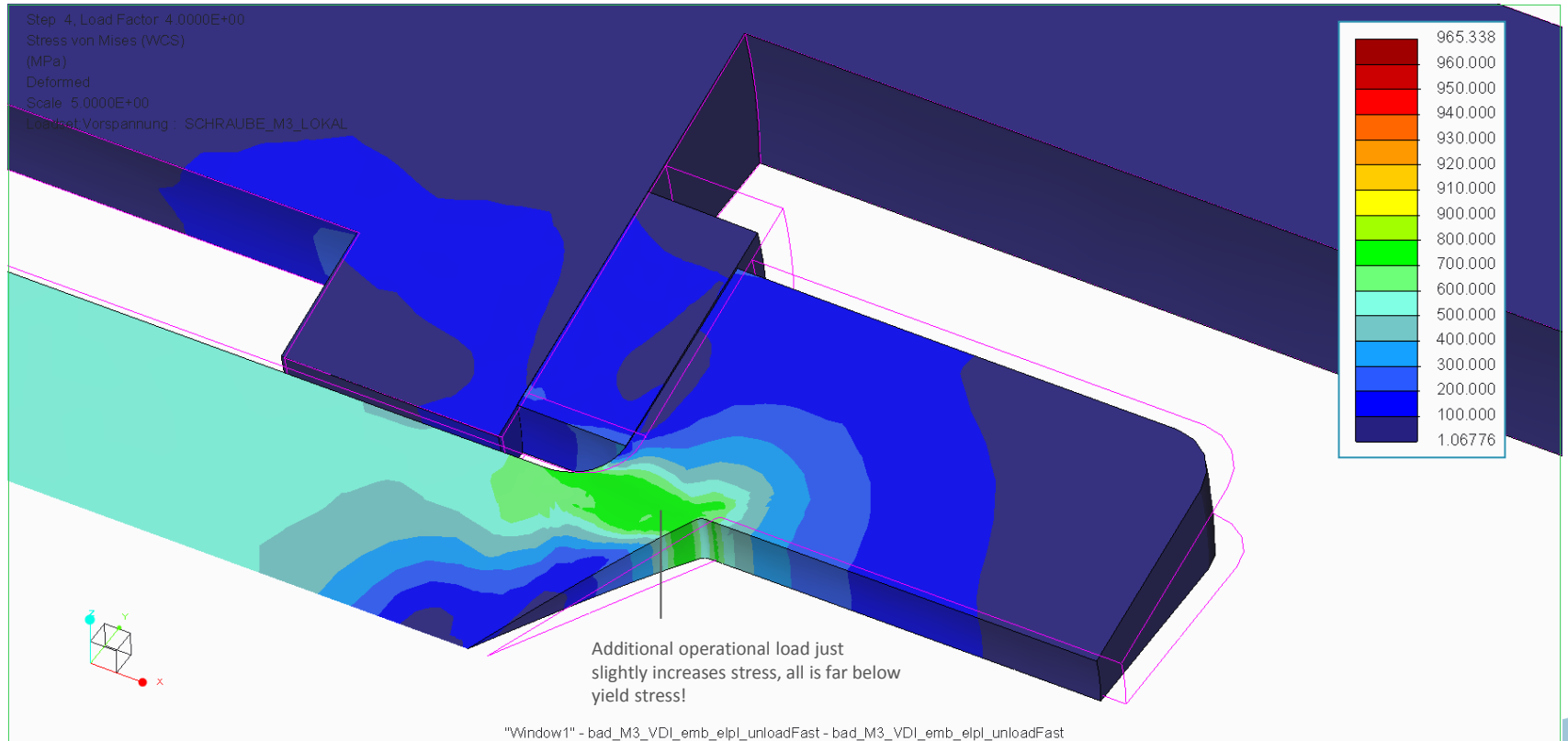

Part B: Advanced Application Examples

1. Bolts with elasto-plasticity and complex load history (tightening, embedding)

Equivalent plastic strain results (step 1)

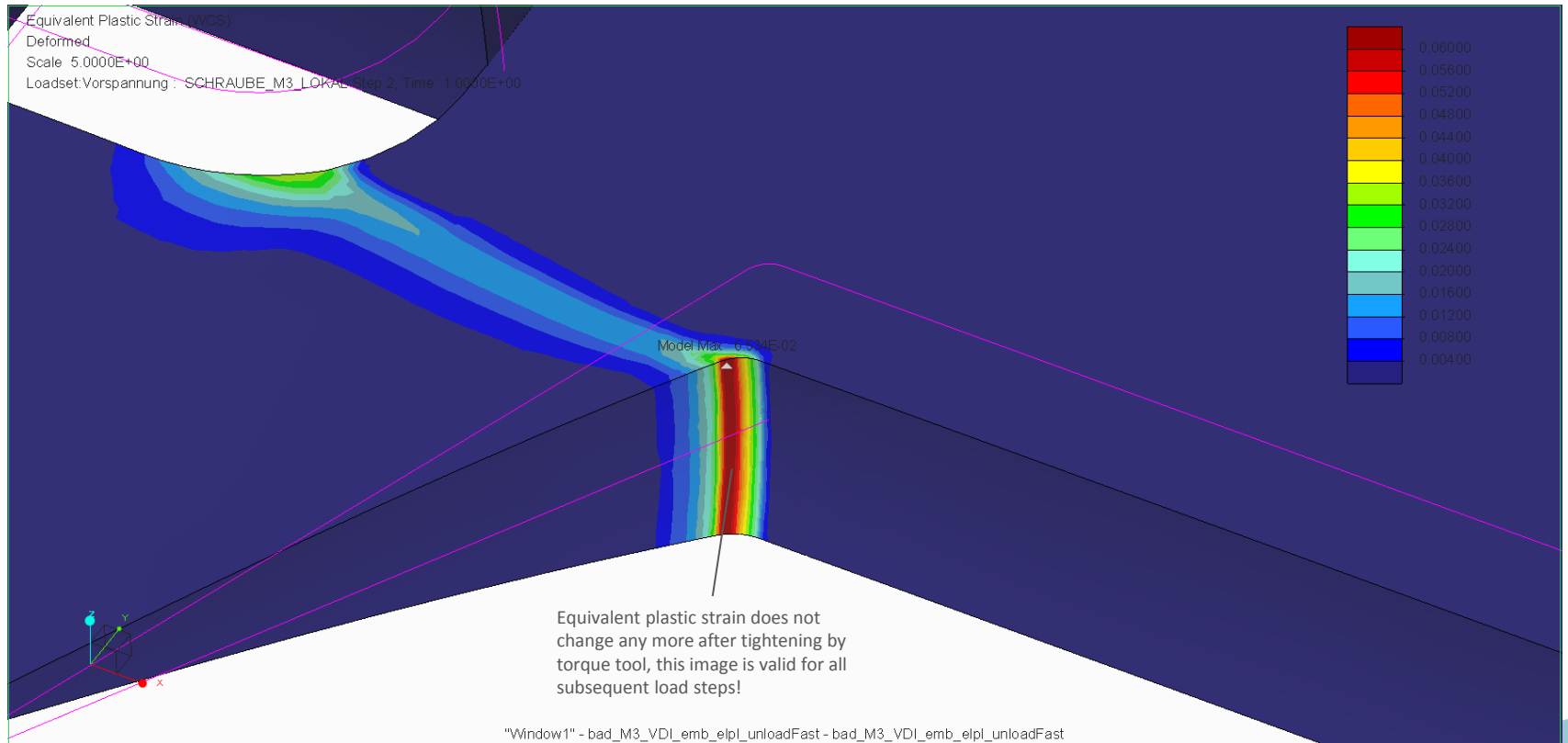

Part B: Advanced Application Examples

1. Bolts with elasto-plasticity and complex load history (tightening, embedding)

Conclusions:

- Torque removal, but especially embedding after tightening leads to a significant stress lowering, so that later operational loads are below tightening loads
- Additionally undertaken fatigue analyses with FEMFAT show that cyclic loading is no problem, too
- The analysis results were proven in tests: In a complete system test, the flange connection, connected with bad bolts having the manufacturing defect, did not fail
- No economic damage, because no time consuming and expensive bolt replacement became necessary

Part B: Advanced Application Examples

2. Additional fastener loadings because of thin flanges and eccentric load introduction

Application example

- Initial design idea of a replaceable flange connection given
- A 7.5 cm thick steel flange is bolted with ten M30x100 bolts to a massive steel block
- At its ends, the steel flange is clamped by four hydraulic cylinders
- The complete connection is then loaded cyclically (Zero-peak)
- The nominal stress of the M30 bolt has to be analyzed for a subsequent fatigue analysis
- If necessary design improvements have to be proposed and analyzed

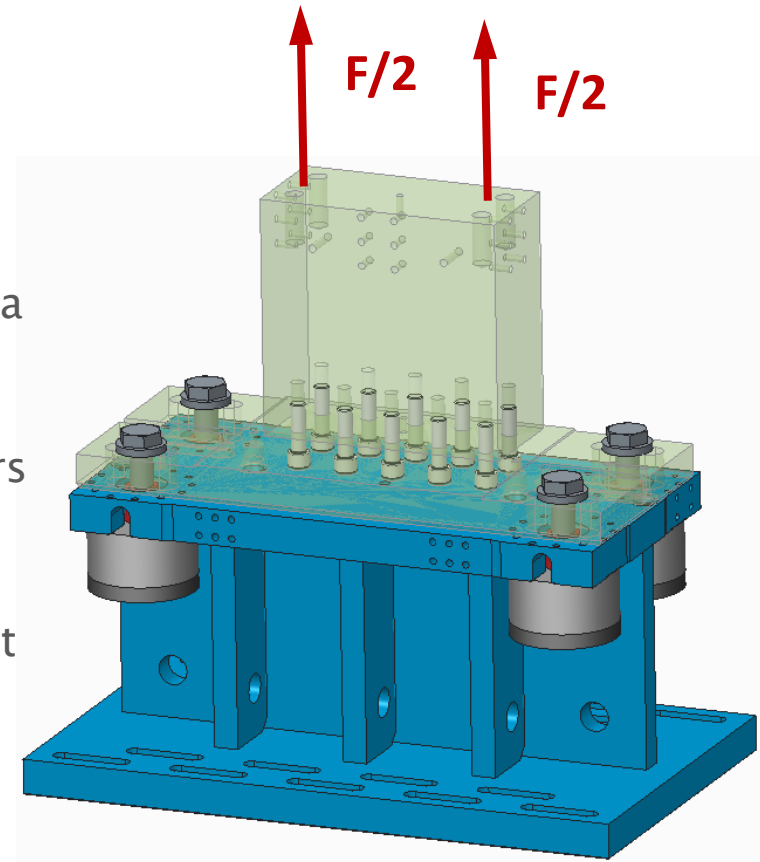

Part B: Advanced Application Examples

2. Additional fastener loadings because of thin flanges and eccentric load introduction

Model setup

- Model class III chosen: Bolts were represented as volumes, but without threaded part (threaded part connected by springs and weighted links)
- Contact between flanges and under the bolt head
- Linear material and SDA contact sufficient
- Half symmetry used

Load steps

- Step 1: Pretension and hydraulic pressure
- Step 2: Operational load

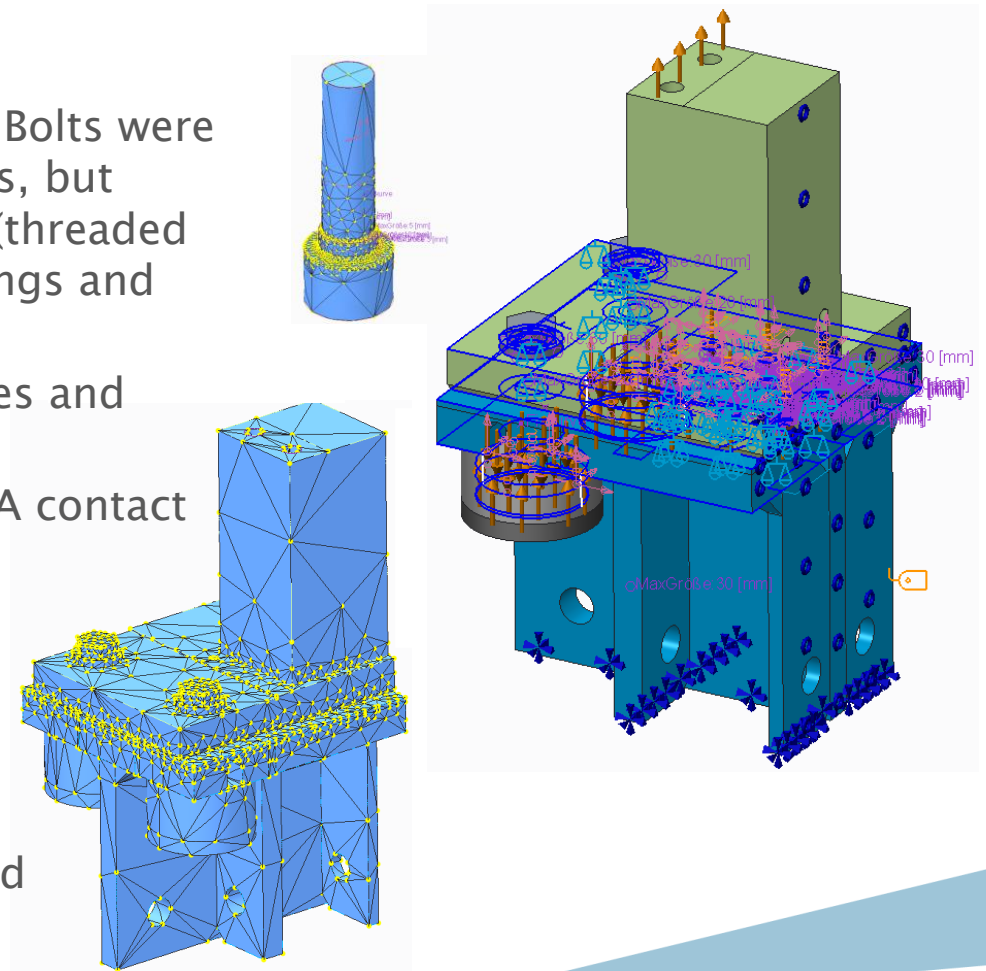

Part B: Advanced Application Examples

2. Additional fastener loadings because of thin flanges and eccentric load introduction

Initial design results

- It turned out that the initial 7.5 cm thick flange was designed too thin to prevent additional bending stresses within the eccentrically loaded bolts
- The nominal stress within the shaft of the outer bolts was therefore significantly above yield, but below rupture strength
- During test operation the complete bolted connection failed after 41 000 load cycles
- The fatigue analysis performed with the stress results from the FEM analysis predicted 95% failure probability for this number of load cycles

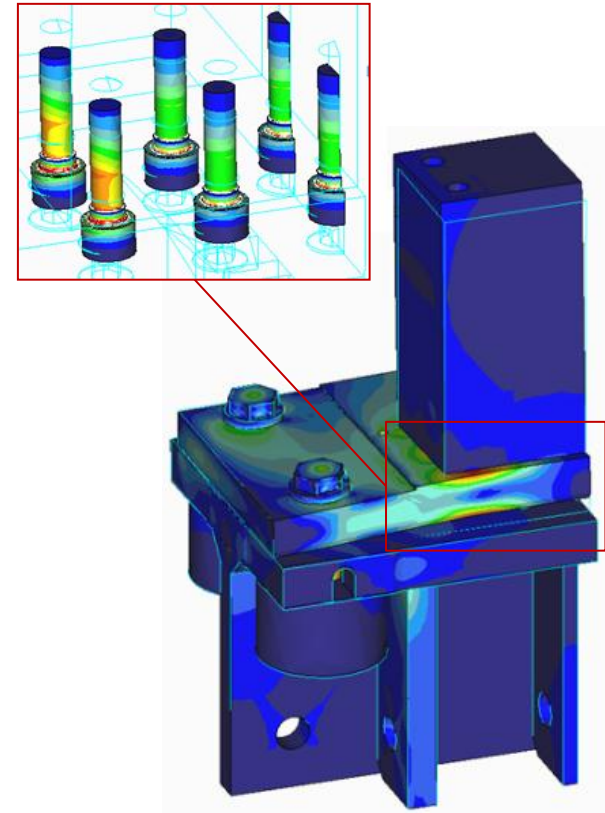

Part B: Advanced Application Examples

2. Additional fastener loadings because of thin flanges and eccentric load introduction

Improved design results

- The flange was thickened up to 24.5 cm to minimize flange bending
- Short bolts have been replaced by longer bolts
- Bolt loading is now nearly bending–stress free and sufficient fatigue strength assured

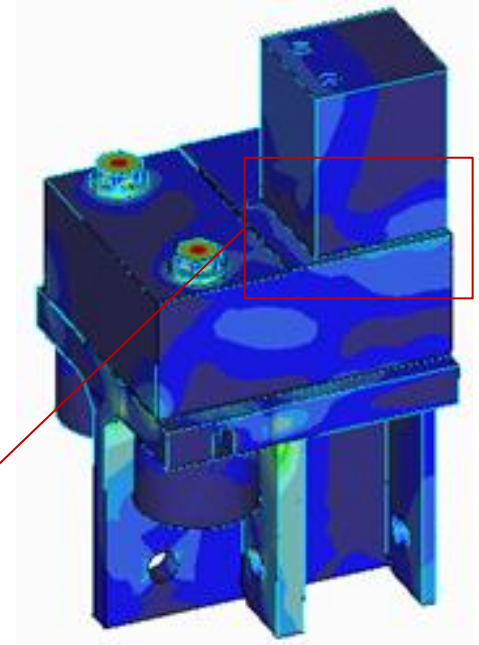
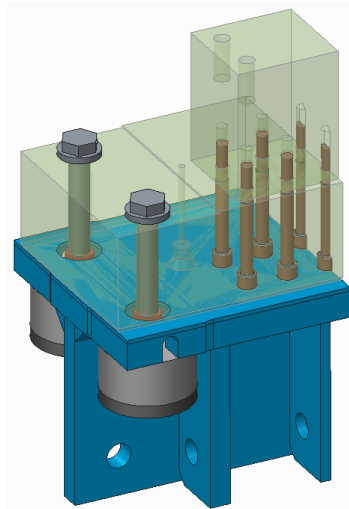
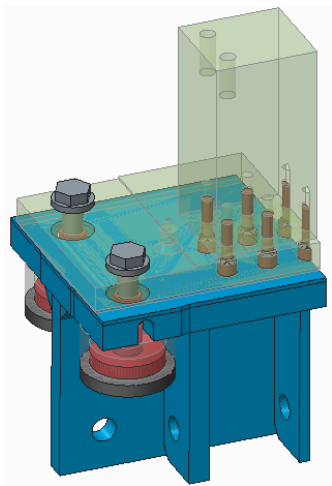

INNOVATION MAKERS

Thanks for your attention!

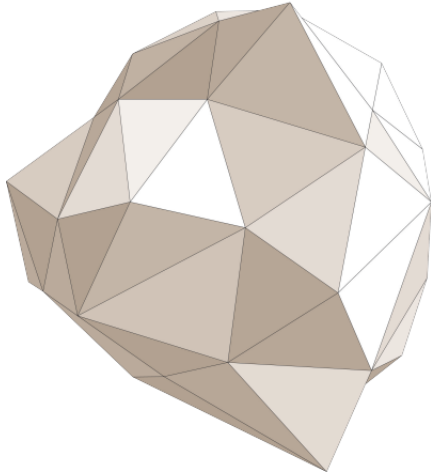

For any questions or services,
please contact the author under
roland.jakel@altran.com

Part C: Appendix

1. List of Sources
2. Acknowledgement

Part C: Appendix

1. List of Sources

- [1] VDI-Guideline 2230 Part 1: Systematic calculation of high duty bolted joints; Joints with one cylindrical bolt, February 2003 edition
- [2] VDI-Guideline 2230 Part 2: Systematic calculation of high duty bolted joints; Joints with multiple bolts, November 2011 draft edition
- [3] R. Jakel: Berechnung von Verschraubungsgeometrien mit einem negativen Kraftverhältnis in Pro/MECHANICA; Vortrag zum 10. Bayreuther Konstrukteurstag; 24. September 2008 (can be downloaded from www.saxsim.de)



Part C: Appendix

1. List of Sources

- [4] R. Jakes: The Mechanical Fastener Feature Functions/Options Matrix, Rev. 1.8; available within the Pro/ENGINEER Mechanical WF5 „Best Practice“ CD by Urs Simmler, PTC

Schraubentypen in Pro/MECHANICA Wildfire 2 und 3: Funktions-/Optionsmatrix

Pro/MECHANICA Funktion	Pro/MECHANICA Funktion	Pro/MECHANICA Funktion	Pro/MECHANICA Funktion	Pro/MECHANICA Funktion	Pro/MECHANICA Funktion	Pro/MECHANICA Funktion
Pro/MECHANICA Funktion Schraubentypen in Pro/MECHANICA Wildfire 2 und 3: Funktions-/Optionsmatrix	Pro/MECHANICA Funktion Schraubentypen in Pro/MECHANICA Wildfire 2 und 3: Funktions-/Optionsmatrix	Pro/MECHANICA Funktion Schraubentypen in Pro/MECHANICA Wildfire 2 und 3: Funktions-/Optionsmatrix	Pro/MECHANICA Funktion Schraubentypen in Pro/MECHANICA Wildfire 2 und 3: Funktions-/Optionsmatrix	Pro/MECHANICA Funktion Schraubentypen in Pro/MECHANICA Wildfire 2 und 3: Funktions-/Optionsmatrix	Pro/MECHANICA Funktion Schraubentypen in Pro/MECHANICA Wildfire 2 und 3: Funktions-/Optionsmatrix	Pro/MECHANICA Funktion Schraubentypen in Pro/MECHANICA Wildfire 2 und 3: Funktions-/Optionsmatrix
Pro/MECHANICA Funktion Schraubentypen in Pro/MECHANICA Wildfire 2 und 3: Funktions-/Optionsmatrix	Pro/MECHANICA Funktion Schraubentypen in Pro/MECHANICA Wildfire 2 und 3: Funktions-/Optionsmatrix	Pro/MECHANICA Funktion Schraubentypen in Pro/MECHANICA Wildfire 2 und 3: Funktions-/Optionsmatrix	Pro/MECHANICA Funktion Schraubentypen in Pro/MECHANICA Wildfire 2 und 3: Funktions-/Optionsmatrix	Pro/MECHANICA Funktion Schraubentypen in Pro/MECHANICA Wildfire 2 und 3: Funktions-/Optionsmatrix	Pro/MECHANICA Funktion Schraubentypen in Pro/MECHANICA Wildfire 2 und 3: Funktions-/Optionsmatrix	Pro/MECHANICA Funktion Schraubentypen in Pro/MECHANICA Wildfire 2 und 3: Funktions-/Optionsmatrix
Pro/MECHANICA Funktion Schraubentypen in Pro/MECHANICA Wildfire 2 und 3: Funktions-/Optionsmatrix	Pro/MECHANICA Funktion Schraubentypen in Pro/MECHANICA Wildfire 2 und 3: Funktions-/Optionsmatrix	Pro/MECHANICA Funktion Schraubentypen in Pro/MECHANICA Wildfire 2 und 3: Funktions-/Optionsmatrix	Pro/MECHANICA Funktion Schraubentypen in Pro/MECHANICA Wildfire 2 und 3: Funktions-/Optionsmatrix	Pro/MECHANICA Funktion Schraubentypen in Pro/MECHANICA Wildfire 2 und 3: Funktions-/Optionsmatrix	Pro/MECHANICA Funktion Schraubentypen in Pro/MECHANICA Wildfire 2 und 3: Funktions-/Optionsmatrix	Pro/MECHANICA Funktion Schraubentypen in Pro/MECHANICA Wildfire 2 und 3: Funktions-/Optionsmatrix

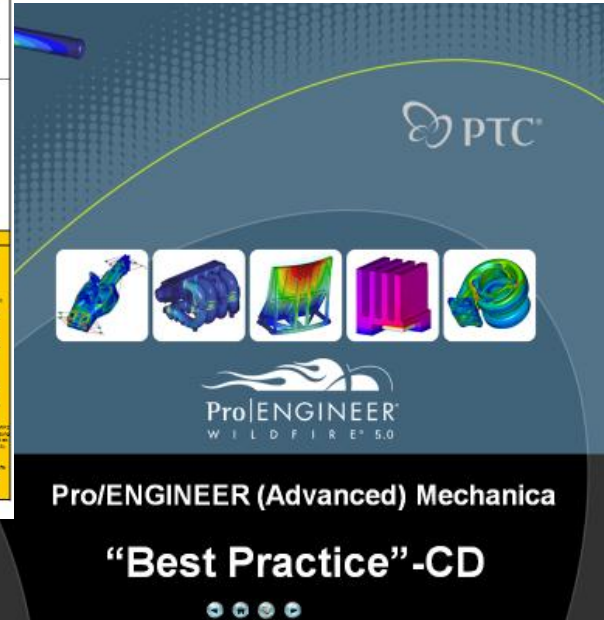

Part C: Appendix

1. List of Sources

- [5] R. Jakel: Numerical analysis of bolted connections with direct load introduction into the bolt head; VDI-Fachtagung Schraubenverbindungen; Dresden, 5. Oktober 2005 (VDI proceedings/conference transcript available)



Numerische Analyse von Schraubenverbindungen bei direkter Lasteinleitung in den Schraubenkopf

Numerical analysis of bolted connections with direct load introduction into the bolt head

Dr.-Ing. Roland Jakel, DENC AG, Langenfeld/Rheinland

Kurzfassung

Die VDI-Richtlinie 2230 gibt sehr detaillierte Berechnungshinweise für Verschraubungen, bei denen die Einleitung der Betriebslast innerhalb des Flansches (in der Richtlinie „Platten“ genannt) stattfindet. In diesem Fall liegt der Richtwert „ n “ für den Ort der Kräfteinleitung innerhalb der Klemmlänge zwischen 0 und 1, siehe Bild 1.



Bild 1: Unbekannter n -Wert bei Lasteinleitung in den Schraubenkopf (ganz links) sowie Schätzungen für Kräfteinleitungsfaktoren nach der alten VDI-Richtlinie von 1986 [1] (rechts)

In der industriellen Praxis tritt jedoch auch der Fall auf, dass die Betriebslast nicht in die Platten, sondern direkt in die Schraube bzw. den Schraubenkopf eingeleitet wird (siehe Bild 1 links), wie dies z.B. bei Spurstangen im Automobilbau oder Tragstreben in der Luft- und Raumfahrttechnik geschieht. Eine solche Verbindung kann nicht mit der VDI-Richtlinie 2230 berechnet werden, da für diesen Anwendungsfall der n -Wert nicht mehr definiert ist.

Part C: Appendix

1. List of Sources

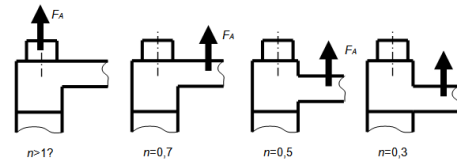
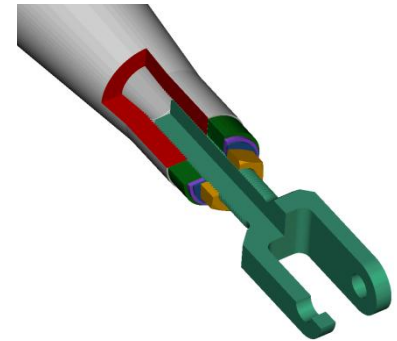
- [6] R. Jakel, N. Schneider: FEM–Simulation einer Kreuzkopfverschraubung Teil 2 – Analyse der Schraubenverbindung; 6th DENC/PTC Simulation User’s Meeting, Darmstadt, April 4, 2006 (can be downloaded from www.saxsim.de)

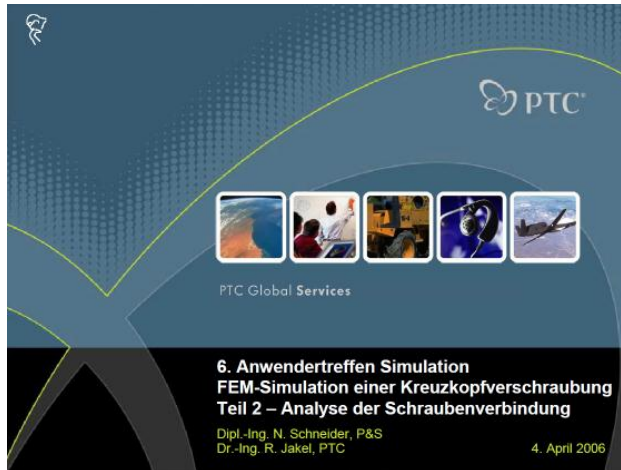

- [7] R. Jakel: Basics of Elasto–Plasticity in Creo Simulate – Theory and Application; Presentation for the 4th SAXSIM, TU Chemnitz, Germany, 17.04.2012; Revision 2.1 (can be downloaded from www.saxsim.de)

Part C: Appendix

2. Acknowledgement

Acknowledgement

Thanks to Christos Katsis, Tad Doxsee and Richard B. King from PTC Simulation Products R&D, for all discussions, the support and providing many useful information!